



No. 4 1972

issued quarterly

Technical Review

To Advance Techniques in Acoustical, Electrical and Mechanical Measurement

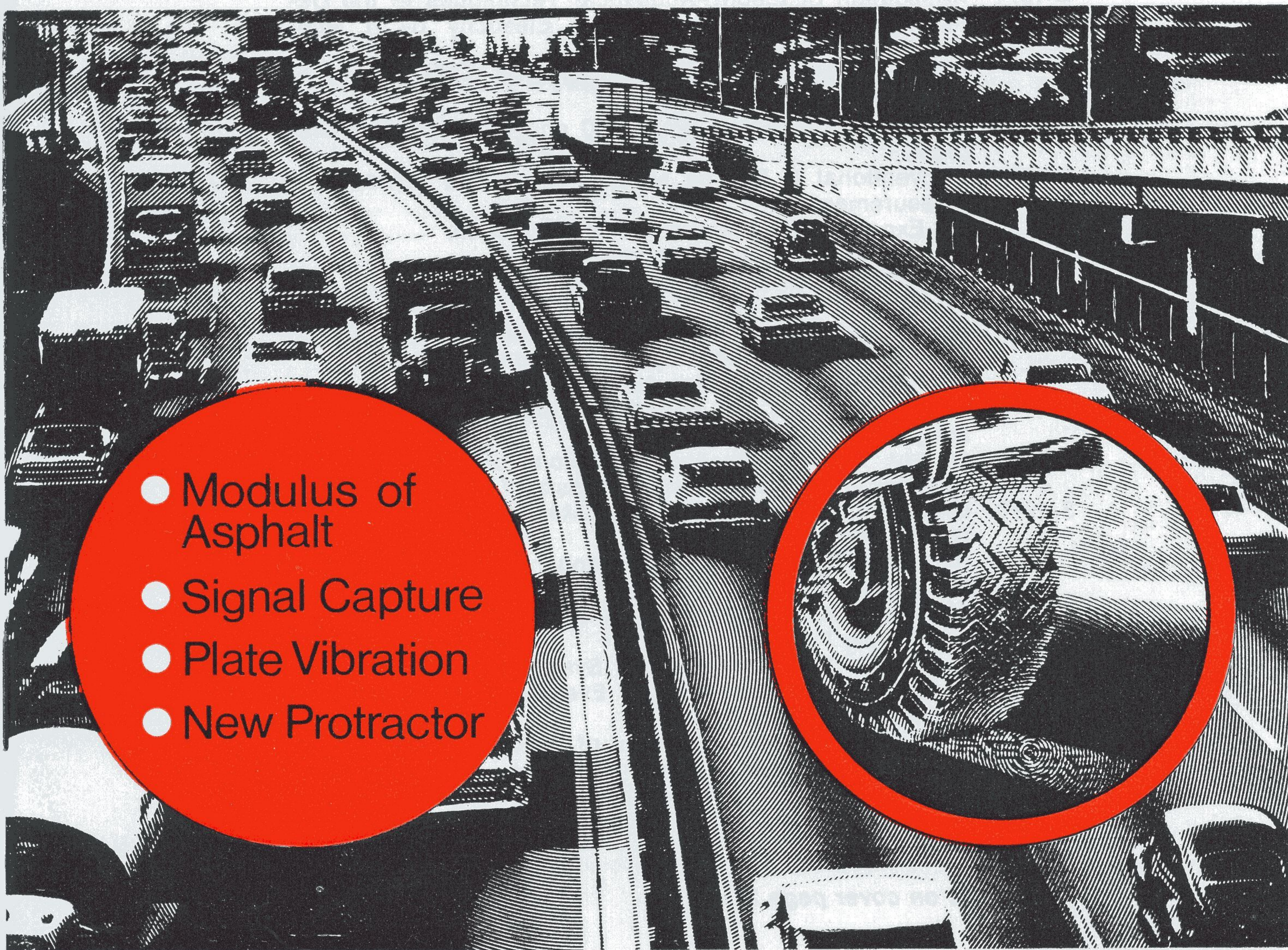

- Modulus of Asphalt
- Signal Capture
- Plate Vibration
- New Protractor

BRÜEL & KJÆR

**PREVIOUSLY ISSUED NUMBERS OF
BRÜEL & KJÆR TECHNICAL REVIEW**

- 3-1972 Thermal Noise in Microphones and Preamplifiers.
High Frequency Response of Force Transducers.
Measurement of Low Level Vibrations in Buildings.
Measurement of Damping Factor Using the Resonance Method.
- 2-1972 RMS-Rectifiers.
Scandinavian Efforts to Standardize Acoustic.
Response in Theaters and Dubbing Rooms.
Noise Dose Measurements.
- 1-1972 Loudness Evaluation of Acoustic Impulses.
Computer Programming Requirements for Acoustic Measurements.
Computer Interface and Software for On-Line Evaluation of Noise Data.
Evaluation of Noise Measurements in Algol-60.
- 4-1971 Application of Electro-Acoustical Techniques to the Determination of the Modulus of Elasticity by a Non-Destructive Process.
Estimation of Sound Pressure Levels at a Distance from a Noise Source.
Acoustical Calibrator Type 4230 and its Equivalent Diagram.
- 3-1971 Conventional & On-line Methods of Sound Power Measurements.
An Experimental Channel Selector System.
- 2-1971 Interchangeable Head Vibration Exciters.
AEROS: A Generalized-Spectrum Vibration-Control System.
- 1-1971 Shock and Vibration Isolation of a Punch Press.
Vibration Measurement by a Laser Interferometer.
A portable Calibrator for Accelerometers.
Electro Acoustic Ear Impedance Indicator for Medical Diagnosis.
- 4-1970 On the Applicability and Limitations of the Cross-Correlation and Cross-Spectral Density Techniques.
- 3-1970 On the Frequency Analysis of Mechanical Shocks and Single Impulses.
Important Changes to the Telephone Transmission Measuring System.
- 2-1970 Measurement of the Complex Modulus of Elasticity of Fibres and Folios.
Automatic Recording-Control System.
- 1-1970 Acoustic Data Collection and Evaluation with the Aid of a Small Computer.
1/3 Octave Spectrum Readout of Impulse Measurements
- 4-1969 Real Time Analysis.
Field Calibration of Accelerometers.
The Synchronization of a B & K Level Recorder Type 2305 for Spatial Plotting.

(Continued on cover page 3)

TECHNICAL REVIEW

No. 4 — 1972

Contents

Measurement of Elastic Modulus and Loss Factor of Asphalt by K. Zaveri and H.P. Olesen	3
The Digital Event Recorder Type 7502 by F. Madsen and H. Straarup	16
Determination of the Radii of Nodal Circles on a Circular Metal Plate by F.W. Ravenhall and A.K. Som	22
Brief Communications New Protractor for Reverberation Time Measurements by Alberto Behar and Jorge Menyhart	28
News from the factory	33

Measurement of Elastic Modulus and Loss Factor of Asphalt

by

K. Zaveri and H.P. Olesen

ABSTRACT

A forced vibration non-resonance technique is described in this article for the measurement of elastic modulus and loss factor of asphalt. Practical results are obtained in the frequency range of interest 5 Hz to 100 Hz and are found to be in good agreement with published results. Details to be taken care of in experimentation are discussed as well as the advantages and limitations of this technique.

SOMMAIRE

Cet article décrit une technique de vibrations forcées sans résonance pour mesurer le module d'élasticité et le facteur de perte de l'asphalte. On a obtenu des résultats pratiques sur la gamme 5 Hz – 100 Hz et ils sont en accord avec les résultats publiés par ailleurs. Les détails à prendre en compte pour l'expérimentation sont discutés de même que les avantages et limitations de la méthode.

ZUSAMMENFASSUNG

Das Referat behandelt eine Methode zur Messung des Elastizitätsmoduls und des Verlustfaktors von Asphalt mittels erzwungener Biegeschwingungen. Die praktischen Resultate, die im interessierenden Frequenzbereich von 5 Hz bis 100 Hz erhalten wurden, stimmen weitgehend mit publizierten Werten überein. Besondere Einzelheiten, die bei der Messung beachtet werden müssen, wie auch die Vorteile und Grenzen des Verfahrens, werden diskutiert.

Introduction

Among the significant properties in the determination of the quality of bituminous mixtures for road pavements are the elastic modulus and the loss factor. These properties are normally measured on sample bars, either cut from a finished road or from a laboratory produced mixture. Several investigators have used various methods for the determination of these dynamic properties either by using tension-compression machines or by exciting the specimens in bending. The conventional resonance method of

determining the modulus of elasticity and loss factor in bending has some limitations when a material such as asphalt is considered. Since the frequency range of interest is below 100 Hz the specimen (rectangular bars for example) would need to be rather long in order to obtain resonances below this frequency, making them inconvenient to be handled in practice. Also the size of the aggregate would limit how thin a specimen could be used.

It was therefore decided to utilize a forced vibration non-resonance technique, where the specimen is simply supported at the ends and excited at its mid-point at constant displacement over the frequency range of interest. (The specimen could also be excited at constant velocity or acceleration). By measuring the force required to excite the specimen and the phase angle between the force and displacement signal, the modulus of elasticity and loss factor can be determined.

Theory

Fig.1 shows a simply supported beam of dimensions $L \times b \times h$ acted upon by a sinusoidal force $P = P_0 \sin \omega_t$ at its mid-point. (In practice the total length of the beam is slightly larger than the distance between the supports).

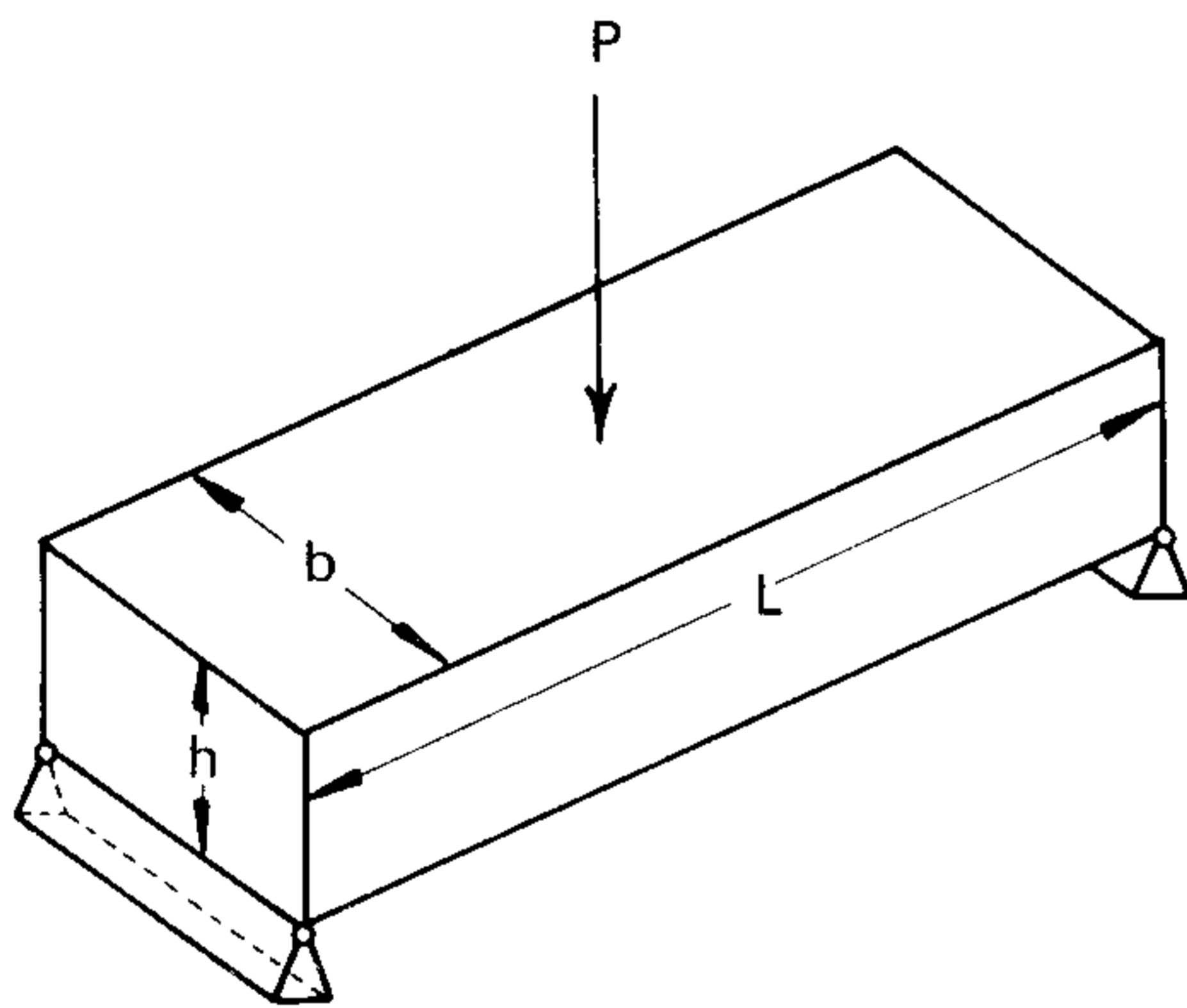
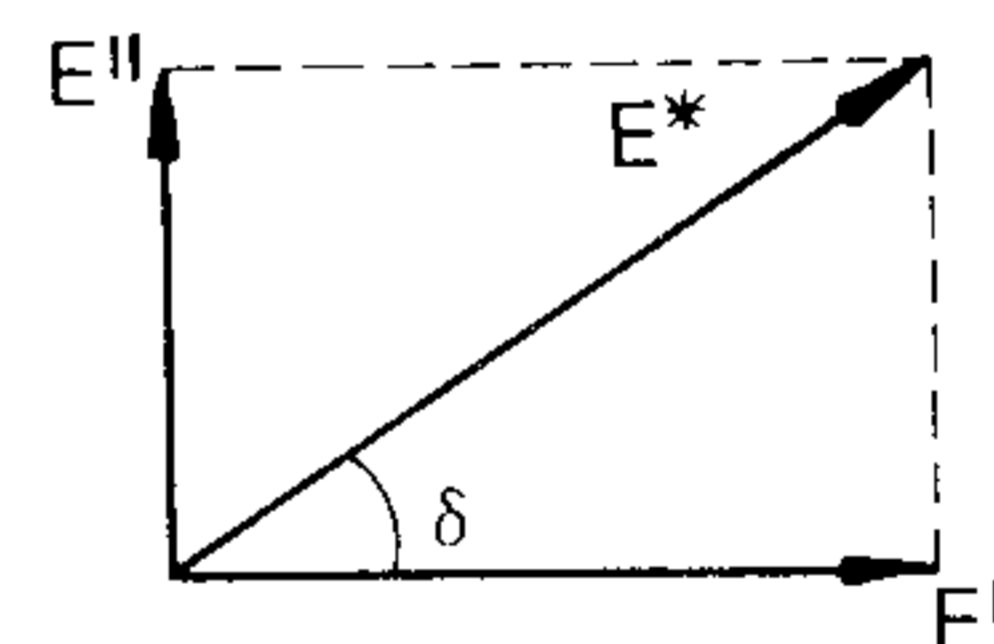

Fig.1. Simply supported beam



272233

Fig.2. Vectorial representation of Complex Modulus of Elasticity

In vector representation the complex modulus E^* Fig.2 for the material is given as

$$E^* = E' + E''$$

where E' = elasticity modulus
and E'' = damping modulus

Often the complex modulus is expressed as

$$E^* = E' (1 + j\eta)$$

where $\eta = \tan \delta$ commonly known as the loss factor
and $j = \sqrt{-1}$

When the specimen is excited by the force P , the displacement y lags behind the force by a phase angle φ on account of the damping present in the material. As shown in Appendix A the elastic modulus E' and the loss factor η can be determined from the formulae given below

$$E' = \left[\frac{P_o}{y_o} \cos \varphi + \frac{4 \pi^2 f^2 LA\rho}{2} \right] \frac{2L^3}{I \pi^4} \quad (2)$$

$$\eta = \left[1 - \frac{y_o}{P_o} \frac{4 \pi^2 f^2 LA\rho}{2 \cos \varphi} \right] \tan \varphi \quad (3)$$

where y_o is the amplitude of vibration at mid-point of specimen in (m)

- φ is the phase angle between force and displacement (degrees)
- f is the frequency of excitation (Hz)
- A is the cross-sectional area of specimen (m^2)
- ρ is the density of the material (kg/m^3)
- I is the second moment of area of cross-section (m^4)

The above formulae are derived from simple theory of bending of rectangular beams, ref. [1]. However, in these equations the deflection due to shear is neglected, as well as the effects of rotatory inertia as it is mostly significant at higher frequencies. It should be noted that in the development of these equations assumption is made that the exciting frequencies are below the first resonance frequency of the beam.

At very low frequencies the second term in parenthesis in both equations are relatively negligible and the equations are simply

$$E' \cong \frac{P_o}{y_o} \cos \varphi \frac{2L^3}{I \pi^4}$$

$$\eta \cong \tan \varphi$$

Since at higher frequencies the force required to accelerate the mass of the specimen becomes significant, the frequency dependent terms in equation (2) and (3) should, therefore, be taken into consideration.

Measuring System

In the measuring set-up shown in Fig.4 a sinusoidal signal is passed from the Exciter Control Type 1026 to the Vibration Exciter Type 4802/4812 via a Power Amplifier Type 2707. The Vibration Exciter excites the specimen

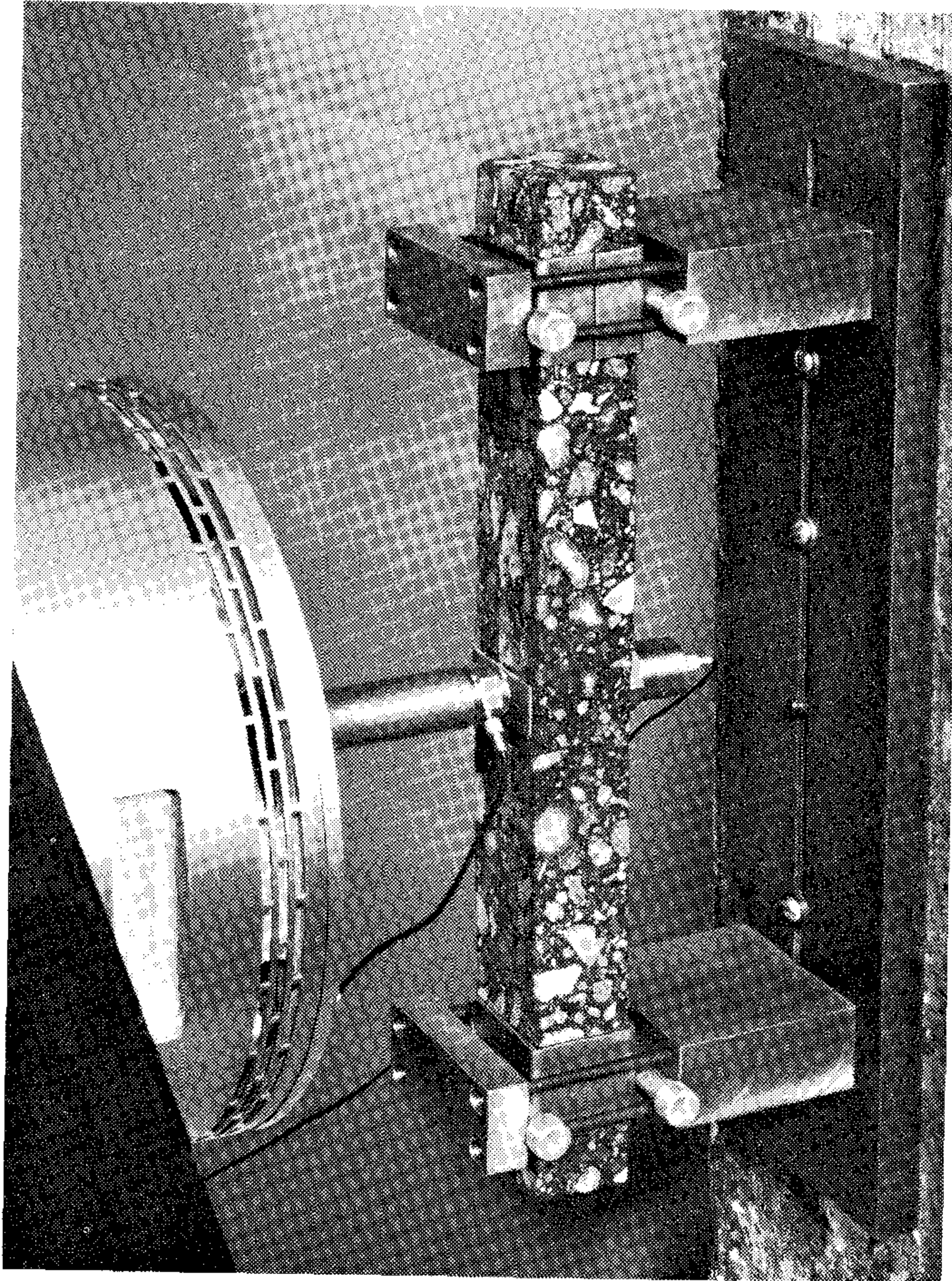

Fig.3. Close-up view of Fixture

through a push rod (which will facilitate possible measurements in a clima chamber) and a Force Transducer Type 8200 which passes a signal, proportional to the force to one of the measuring channels of the Exciter Control via a Conditioning Amplifier Type 2626 and a Slave Filter Type 2021. The acceleration at the mid-point of the specimen is picked up by an accelerometer Type 4338 and the signal is passed on via another Slave Filter Type 2021 to the second measuring channel of the Exciter Control where it is integrated twice to give the displacement of the specimen at its mid-point.

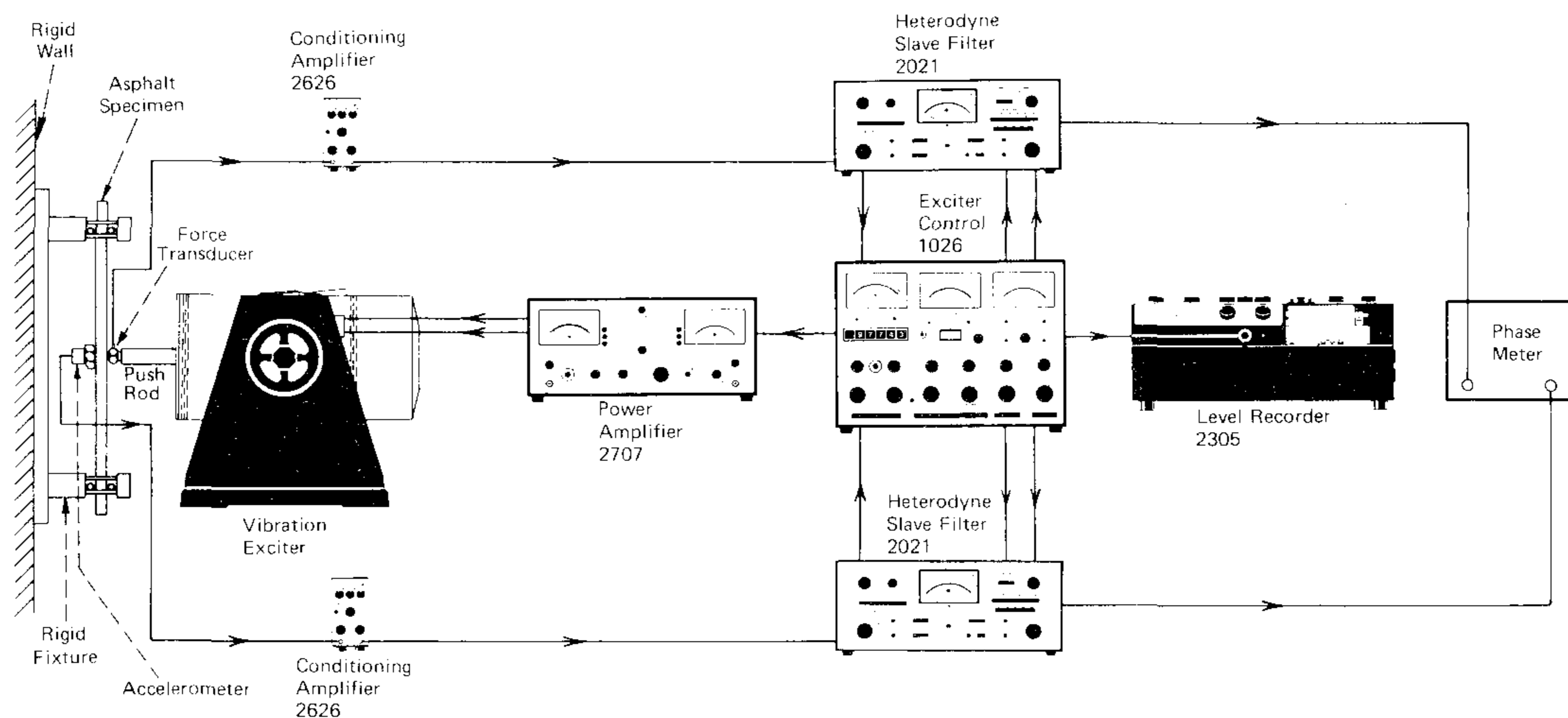

Fig.4. Measuring Instrumentation Set-up

The displacement signal is used in the servo-loop to control the vibration of the specimen to be at constant displacement, while the frequency is scanned automatically over the frequency range of interest. Since the Level Recorder and the Exciter Control are synchronized, the force signal from the measuring channel of the Exciter Control can be registered as a function of frequency on a frequency calibrated paper on the Level Recorder. The force and the acceleration signals from the two slave filters having 3.16 Hz constant bandwidth are taken to a phasemeter for determining the phase angle between the two signals.

The reasons for including the constant bandwidth Slave Filters in the system are twofold. The first one, obviously, to remove noise from the signal to obtain a "cleaner" waveform for the servo-loop and phase measurements, and secondly to utilize the 60 kHz output signals for measuring the phase angle between the force and the acceleration signals.

Measured Results

Measurements were taken on asphalt specimens at different temperatures. Figs.5 and 6 show for two specimens of different aggregate size, how the force varies with frequency for a constant displacement of 0.015 mm (peak) at temperatures 22°C and 25°C. Figs.7 and 8 show the modulus of elasticity and loss factor against frequency evaluated for the specimens at these temperatures.

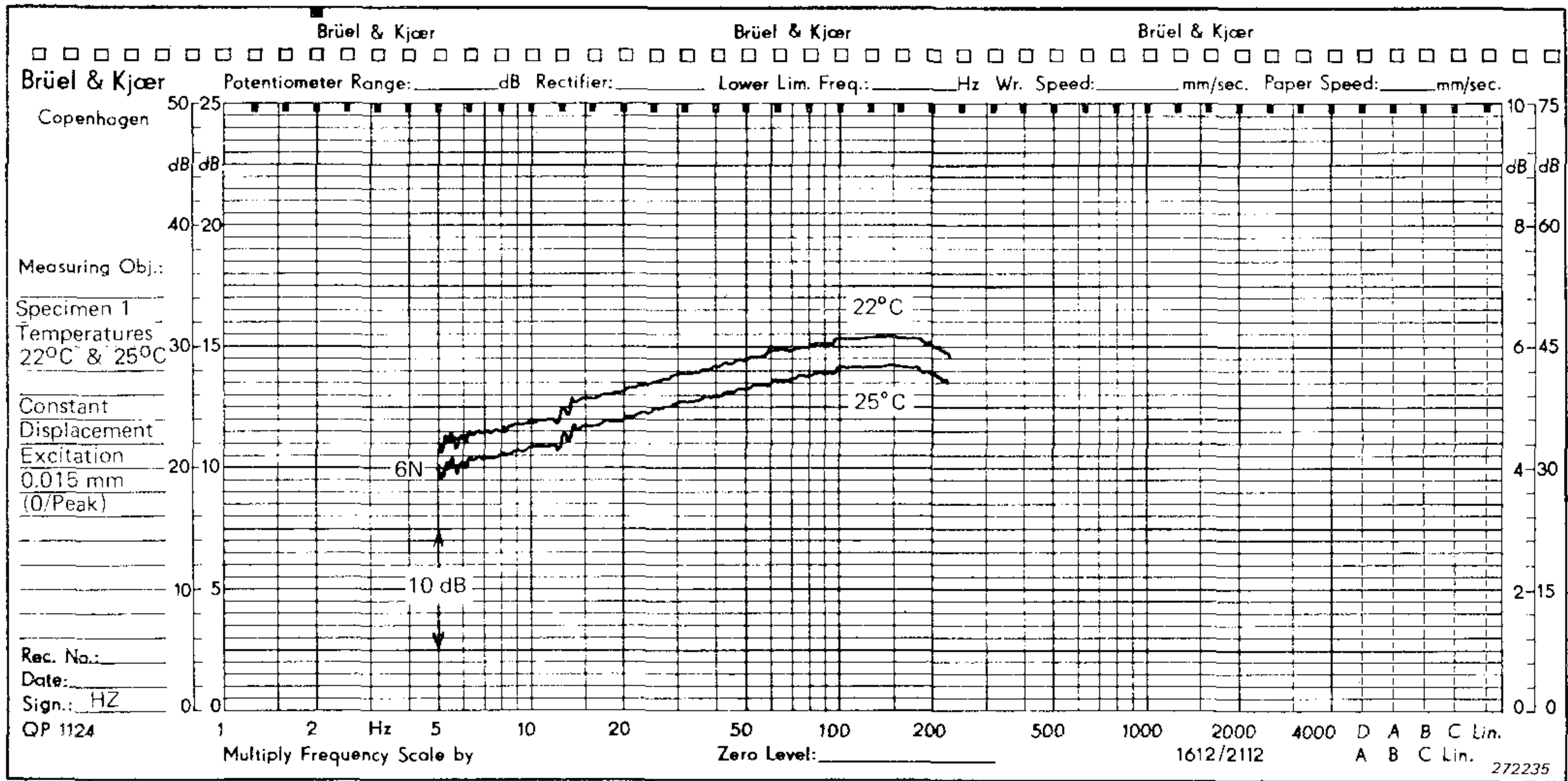

Fig.5. Measured force against frequency for specimen 1

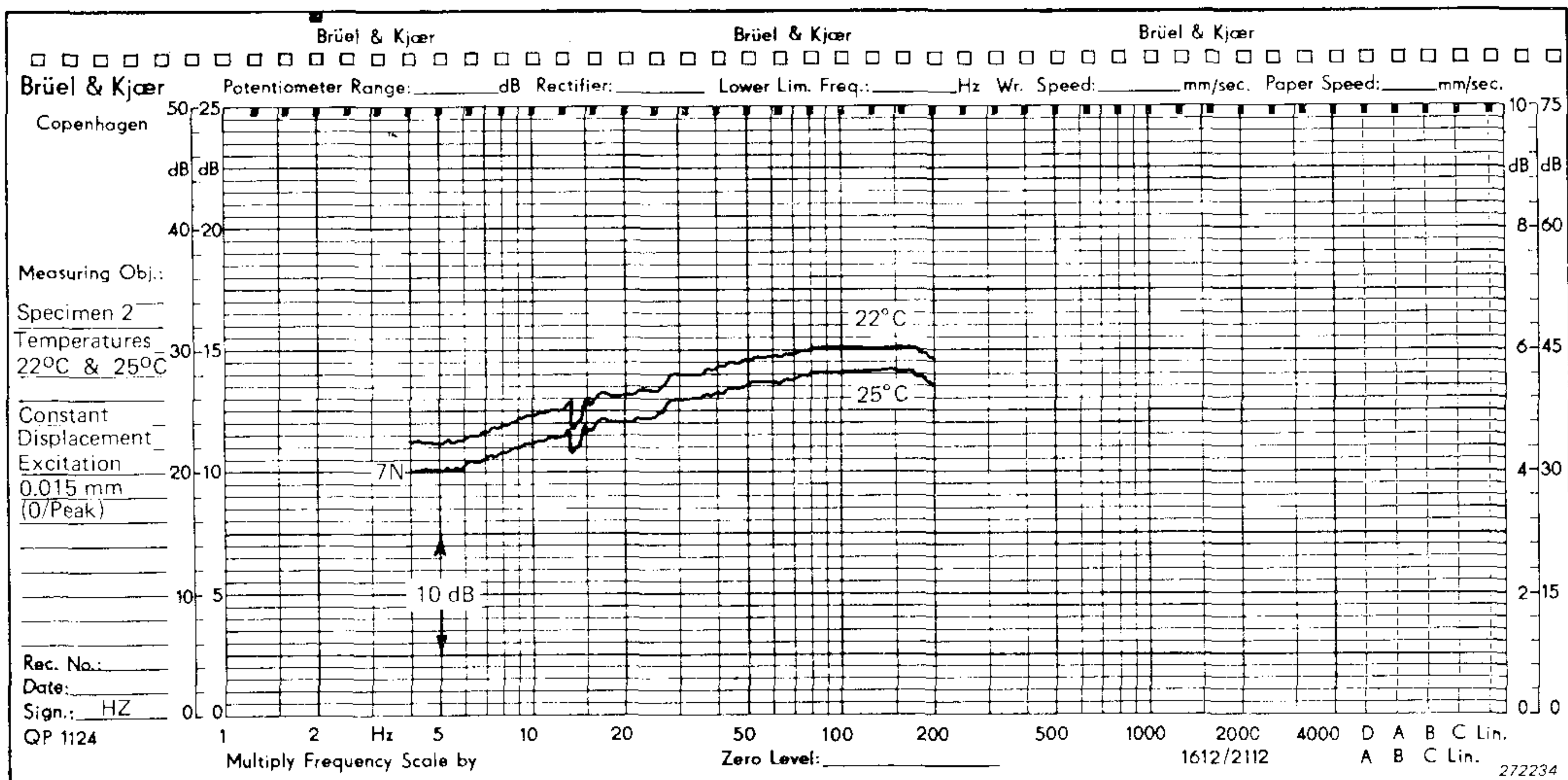
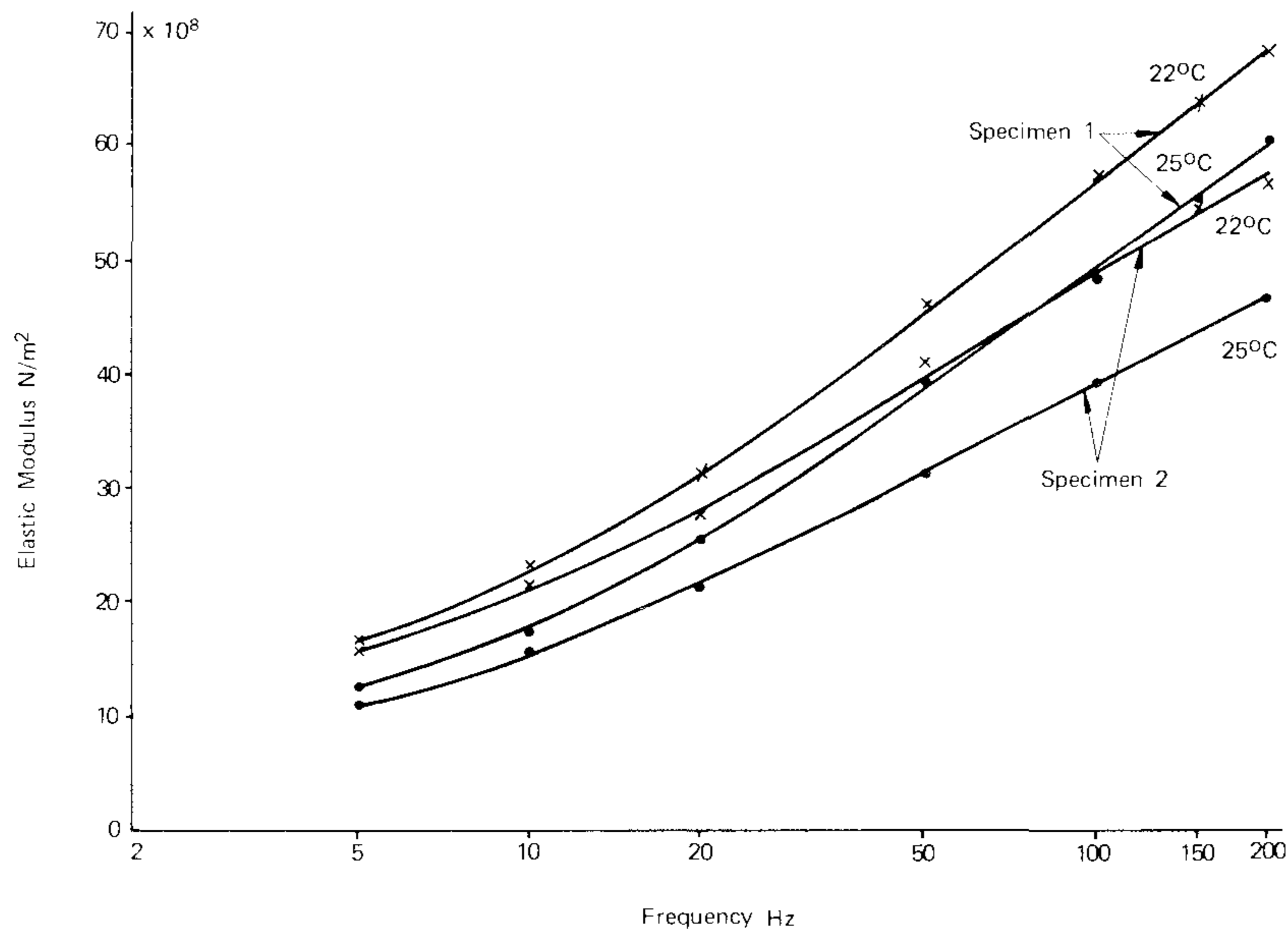
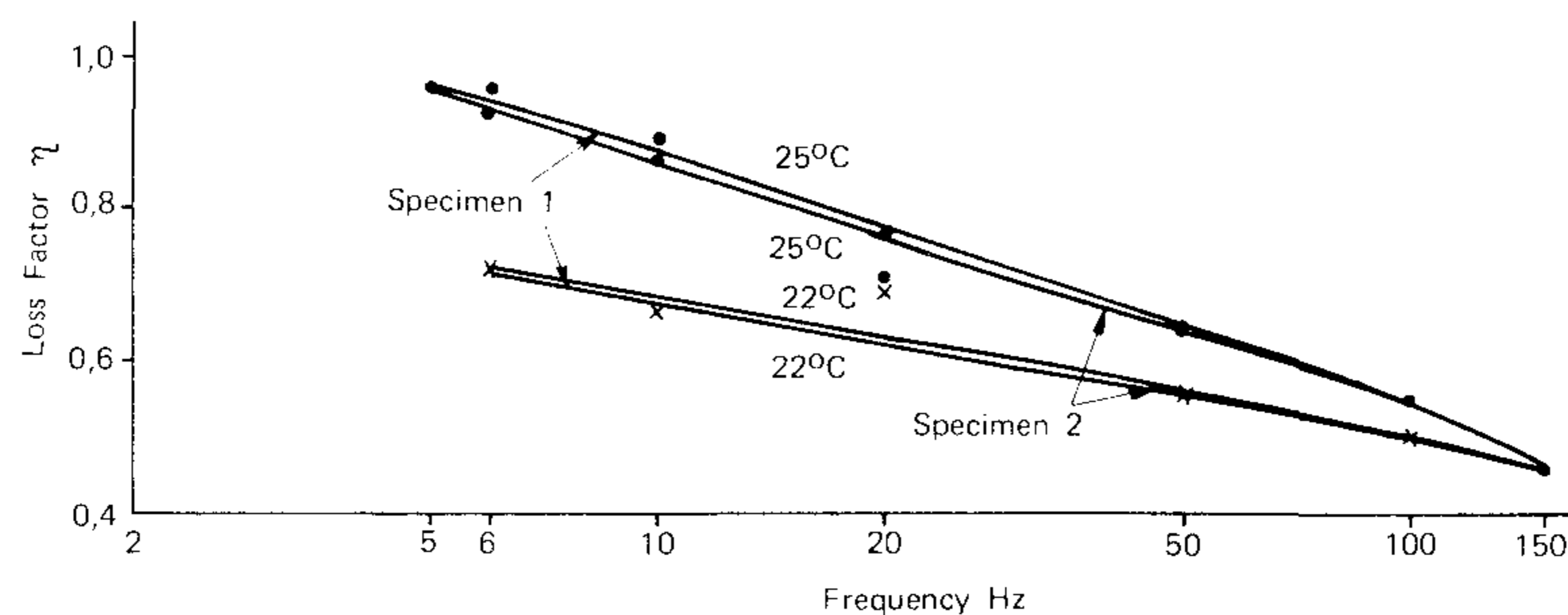

Fig.6. Measured force against frequency for specimen 2



272238

Fig.7. Variation of Modulus of Elasticity of Asphalt with frequency



272237

Fig.8. Variation of Loss Factor of Asphalt with frequency

Discussion

Fig.9 which shows the theoretical variation of elastic and damping moduli at 0°C over the frequency range 10⁻⁷ to 10⁵ Hz is reproduced from Ref. [2]. The moduli values at other temperatures are obtained by sliding the abscissa axis, so that the frequency 10⁰ Hz coincides with the desired temperature. It is interesting to note that at high frequencies or low temperatures, asphalt behaves almost completely elastic, while at low frequencies or high temperatures it exhibits predominantly viscous behaviour. Also at high frequencies or low temperatures the stiffness of asphalt increases considerably, however, the vibration exciter (force capability 445 N peak) used in our experiment would suffice force requirements over greater part of the frequency and temperature range.

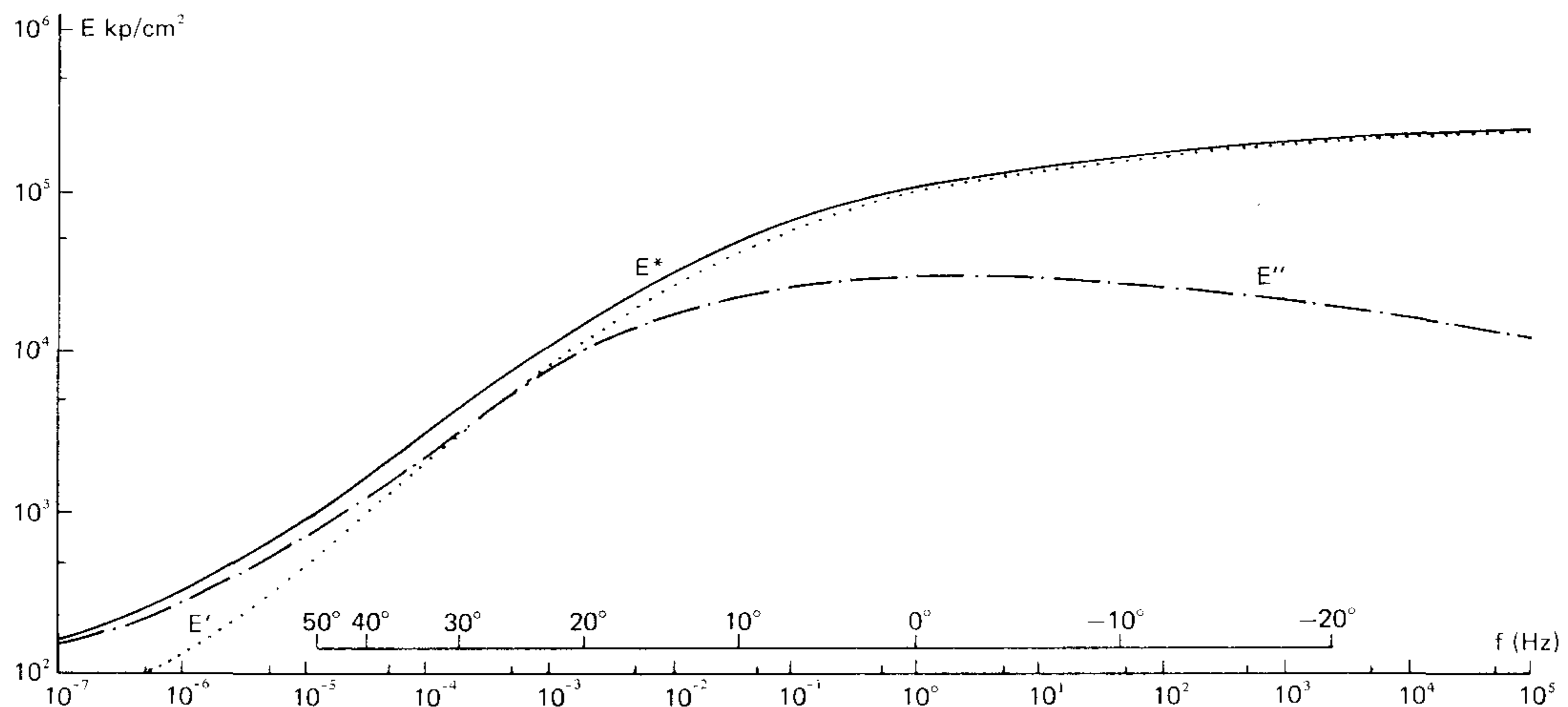

272266

Fig.9. Elastic, Damping and Complex Moduli plotted against frequency. Reproduced from Ref.[2]

There are two particularly attractive features of this system. Firstly, direct mounting of the transducers on the specimens removes the necessity of vectorial addition of interconnected masses to be compensated for. Secondly there is the automatic frequency scanning and measurement data recording facility above 5 Hz, as opposed to time consuming point to point measurements. At frequencies below 5 Hz when the centre frequency approaches 3.16 Hz which is the minimum bandwidth of the slave filters mirror effects makes frequency scanning problematic. However, point to point measurements could be carried out without the slave filters and phase differences would need to be measured between the low frequency signals, either by using an appropriate phase meter or comparing the signals on an oscilloscope. Since in this case, displacement is considered to be the parameter of interest, an accelerometer would not be an ideal transducer below 5 Hz on account of the corresponding very low acceleration levels. A displacement sensitive transducer would therefore be preferable.

To achieve results as accurate as possible a few practical details to be taken care of in experimentation should be mentioned. Firstly, to avoid any mechanical resonances in the system the vibration exciter should be mounted rigidly and the fixture made stiff enough depending on the size of the specimen and the forces required to excite the specimen. Also holding the fixture in a vertical position would remove the possibility of the specimen sagging on account of its own weight. Secondly metal jaws shown in Fig.10 were attached at the ends of the specimen to prevent asphalt being squashed when it is supported in the fixture shown in Fig.3. Also by ensuring that the specimen is not held too rigidly in the fixture, the

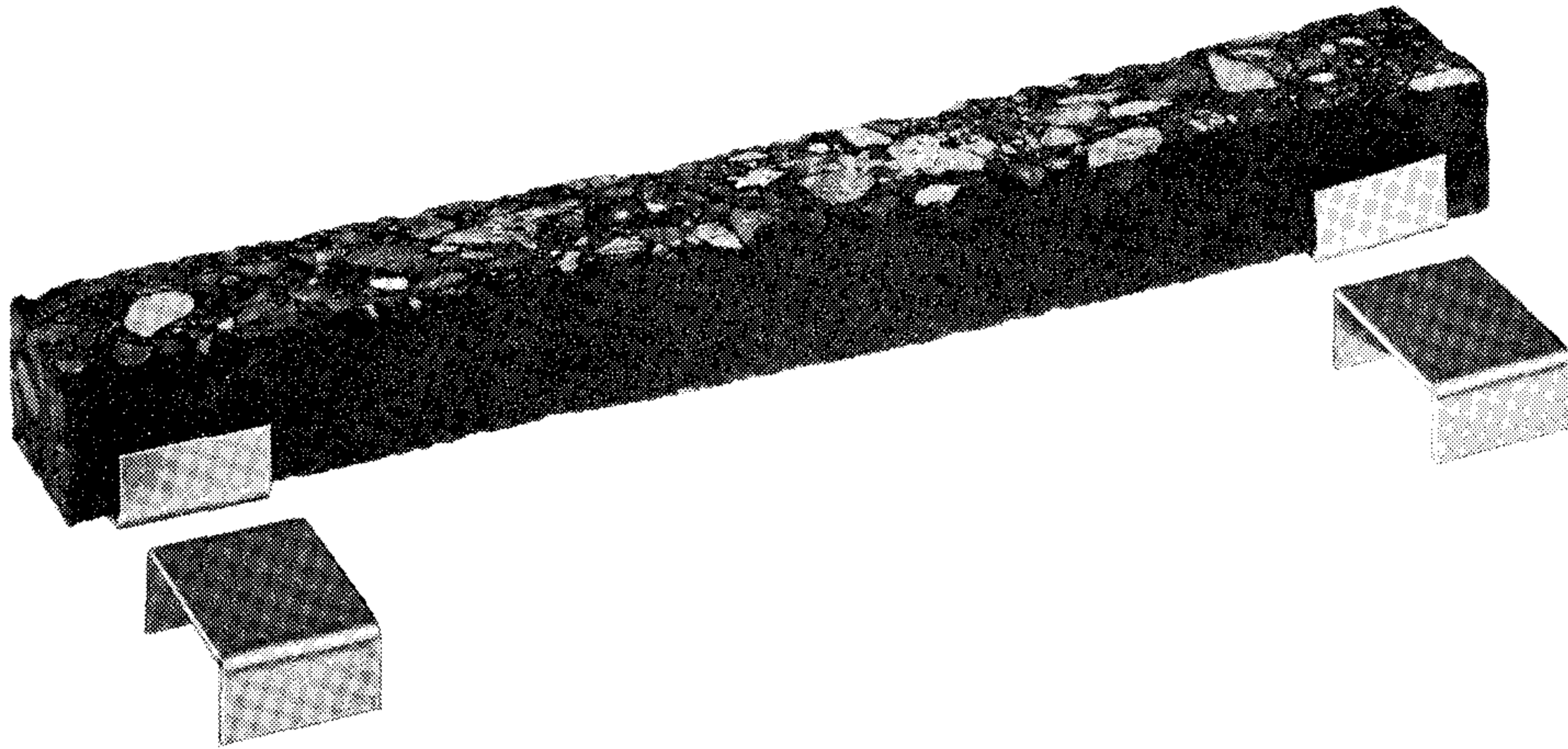

Fig.10. Asphalt specimen and metal jaws

introduction of bending moments and friction at the supports would be reduced to the minimum. Of course, more elaborate fixtures could be developed to reduce these effects even further, by utilizing ball or roller bearings placed in supports which were free to rotate.

It should be noted that the phase change on account of integration of the signal does not come into play as the phase angle between the force signal and the acceleration signal from the slave filter is being measured, before the integration is carried out in the Exciter Control.

Errors in phase measurements would be introduced on account of the phase meter, if the two signals were not of relatively the same magnitude. The problem is, however, overcome by either amplifying or attenuating the signals by the gain adjustments on the Conditioning Amplifiers Type 2626.

Conclusion

The results obtained are found to be in good agreement with published data. One significant advantage of this measuring technique is that the elastic modulus and the loss factor can be determined continuously over the frequency range, as opposed to conventional resonance frequency method where the elastic modulus and loss factor are determined only at the resonance frequency, governed by the dimensions of the specimen and end fixing conditions.

The measuring system is well suited for measurements of the complex modulus of elasticity for materials having a relatively high loss factor. For materials with little internal damping, the elasticity modulus can still be measured, though inaccuracies would be introduced in determining the loss

factor as the phase differences to be measured would be of the order of just a few degrees.

Literature

1. Timoshenko, S: Vibration Problems In Engineering, Third Edition. D. Van Nostrand Company, Inc.
2. Bohn, Axel, O.
Ullidtz, Per and
Stubstad, Richard: Asphaltbelægningers dynamiske Material-Moduler. Den polytekniske Lærestalts Institut for Vejbygning, Trafikteknik og Byplanlægning, meddelelse 47.
3. Van der Poel, C.: A General System Describing the Visco-Elastic Properties of Bitumens and its Relation to Routine Test Data. Shell Bitumen Reprint No. 9.
4. Shook, J.F. and
Kallas, B.F.: Factors Influencing Dynamic Modulus of Asphalt Concrete. Proceedings Association of Asphalt Paving Technologist. Vol. 38, 1969.
5. Van Draat, W.E.F and
Sommer, P.: Ein gerät zur Bestimmung der dynamischen Elasticitätsmoduln von Asphalt . Strasse und Autobahn, Vol. 16, 1965.
6. Heukelom, W. and
Klomp, A.J.G.: Road Design and Dynamic Loading. Proceedings, Association of Asphalt Paving Technologists, Vol 33, 1964.
7. Monismith, C.L.
Alexander R.L.,
Secor, K.E.: Rheologic Behavior of Asphalt Concrete. Proceedings, Association of Asphalt Paving Technologists, Vol 35, 1966.

Appendix A

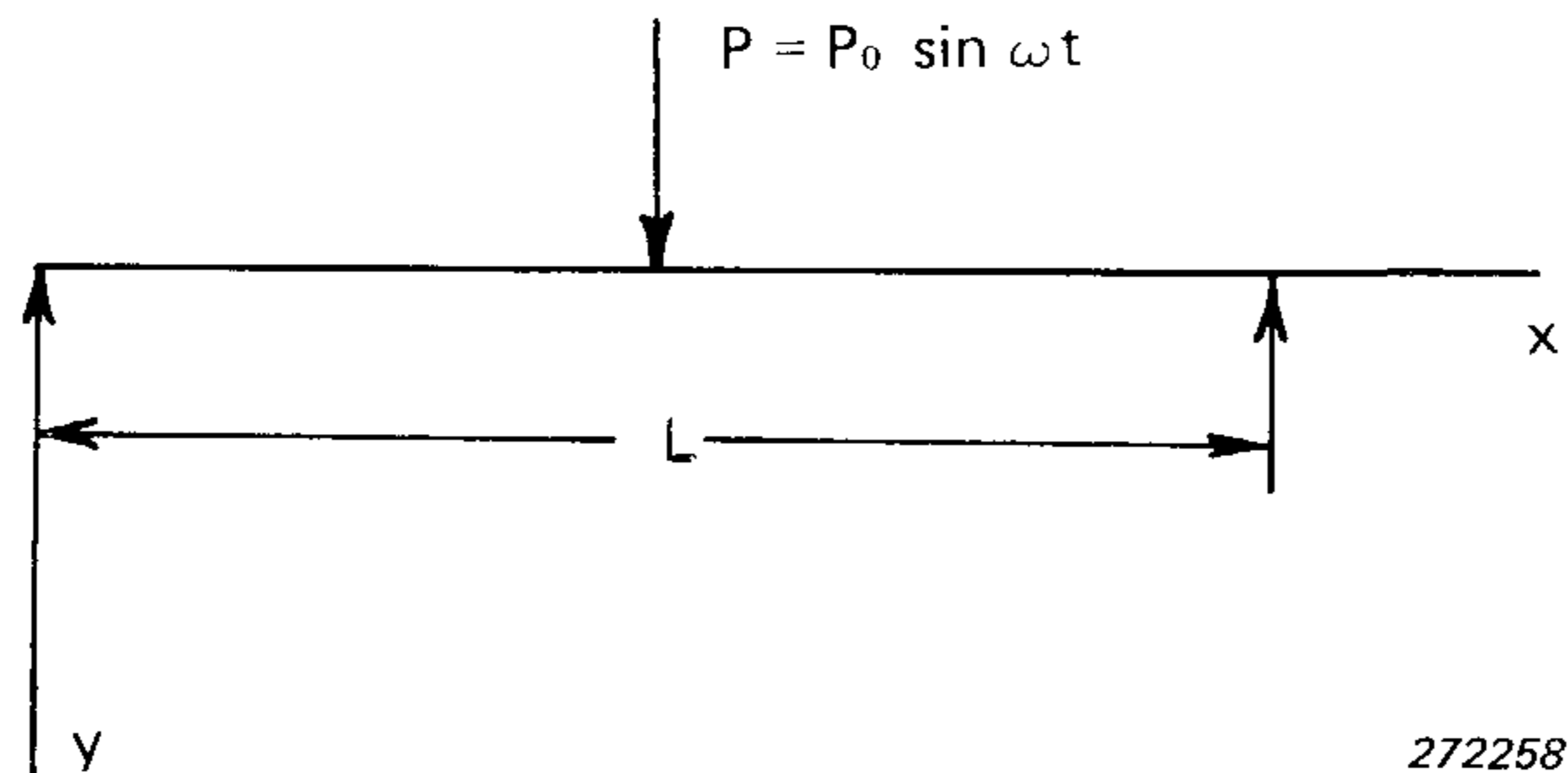

Fig.A1. Simply supported beam

It has been shown in Ref. [1], page 349, that for a sinusoidal exciting force $P = P_0 \sin \omega t$ acting at the mid-point of a simply supported beam, the steady-state deflection $y = y_0 \sin \omega t$ at any point x on the beam at time t is given by the expression

$$y = \frac{2P_0 L^3 \sin \omega t}{E' I \pi^4} \left[\frac{\sin \pi x/L}{1 - \alpha^2} - \frac{\sin 3\pi x/L}{3^4 - \alpha^2} + \frac{\sin 5\pi x/L}{5^4 - \alpha^2} - \dots \right] \quad (A1)$$

where L is the length of the beam
 E' is the elastic Modulus
and I is the 2nd Moment of Area

α is the ratio of exciting frequency to fundamental frequency of free vibration given by

$$\alpha = \frac{\omega L^2}{a \pi^2}$$

where $a = \sqrt{\frac{E'I}{A\rho}}$

A is cross sectional area of beam and ρ is the mass density of the material.

For exciting frequencies below the fundamental frequency i.e. $\alpha < 1$ the first term of the series represents the deflection of the beam with good accuracy. The steady-state deflection at the mid-point of the beam is then given by

$$y = \frac{2P L^3}{E' I \pi^4} \frac{1}{1 - \alpha^2} \quad (\text{A2})$$

Substituting for α and a and rearranging we obtain

$$\frac{P}{y} = \frac{E' I \pi^4}{2L^3} - \frac{\omega^2 LA\rho}{2} \quad (\text{A3})$$

If the material of the beam is considered to possess damping, the force will lead the displacement by an angle φ and the elastic modulus can be replaced by the complex modulus $E^* = E' (1 + j\eta)$,

$$\text{i.e.} \quad \frac{P_o \sin(\omega t + \varphi)}{y_o \sin(\omega t)} = \frac{E' I \pi^4}{2L^3} + \frac{j\eta E' I \pi^4}{2L^3} - \frac{\omega^2 LA\rho}{2}$$

where $\eta = \text{loss factor}$
and $j = \sqrt{-1}$

Taking the modulus and the argument of the equation

$$\frac{P_o}{y_o} = \sqrt{\left(\frac{E' I \pi^4}{2L^3} - \frac{\omega^2 LA\rho}{2}\right)^2 + \left(\frac{\eta E' I \pi^4}{2L^3}\right)^2} \quad (\text{A4})$$

$$\text{and} \quad \tan \varphi = \frac{\frac{\eta E' I \pi^4}{2L^3}}{\left(\frac{E' I \pi^4}{2L^3} - \frac{\omega^2 LA\rho}{2}\right)} \quad (\text{A5})$$

Substituting (A5) in (A4) for η and $\omega = 2\pi f$ we obtain

$$E' = \left[\frac{P_o}{y_o} \cos \varphi + \frac{4\pi^2 f^2 LA\rho}{2} \right] \frac{2L^3}{I \pi^4} \quad (\text{A6})$$

Substituting (A6) in (A5) for E' we obtain

$$\eta = \frac{1}{1 + \frac{y_o}{P_o} \frac{\omega^2 LA\rho}{2 \cos \varphi}} \tan \varphi$$

As relatively low frequencies are considered only the first two terms in the expansion of the series of the type $\eta = \frac{1}{1+x} \tan \varphi$ is considered yielding

$$\eta \cong \left[1 - \frac{y_o}{P_o} \frac{4\pi^2 f^2 LA\rho}{2 \cos \varphi} \right] \tan \varphi \quad (A7)$$

The Digital Event Recorder Type 7502

by

F. Madsen and H. Strårup

ABSTRACT

A new instrument was developed for the capture and recording of single acoustic and vibration events occurring randomly in time. The digital construction presents some important advantages over tape recorder technique, and the working principle, which is explained by means of a block diagram, facilitates a number of suggested applications.

SOMMAIRE

Un nouvel instrument a été développée pour capter et enregistrer les phénomènes acoustiques et vibratoires isolés se produisant de façon aléatoire dans le temps. La réalisation sous forme numérique présente quelques avantages importants par rapport à l'enregistrement magnétique. Le principe de fonctionnement, expliqué grâce à un schéma fonctionnel, facilite un grand nombre d'applications qui sont suggérées.

ZUSAMMENFASSUNG

Es wird ein neues digitales Gerät zur Erfassung und Registrierung von zufällig auftretenden, einmaligen Signalen auf den Gebieten der Akustik und mechanischen Schwingungen vorgestellt. Die Vorteile gegenüber den allgemein üblichen Magnetbandgeräten werden erörtert und das Arbeitsprinzip anhand des Blockschaltbildes erklärt. Anregungen für die Anwendung werden gegeben.

Introduction

To automatically read single events occurring randomly in time one can either use a combination of tape recorder technique and logic circuitry or use digital circuits throughout the system.

Magnetic tape recording on good quality FM tape recorders provides a very reliable means of recording electrical signals from various sources, the signals are recorded permanently and economically and the recorded signal can be played back repeatedly by forming the magnetic tape into a loop. However, the tape recorder has normally only a limited number of available speeds and mechanical wear, especially on tape loops, presents a problem.

A digital solution, on the other hand, would demand a large number of electronic components, the storage capacity would be restricted from economic reasons and permanent records would be unrealistic. However, some very attractive advantages are directly obtainable, such as elimination of all wearable mechanical parts, direct compatibility with other digital instruments and, not the least, a practically non-limited range of recording and play-back speeds.

As the above advantages could be obtained at a competitive price the digital solution was chosen and a Digital Event Recorder was developed to record single events and play them back either for frequency analysis or recording on level recorders or digital equipment.

Principle of operation

The main elements of the Digital Event Recorder are shown in the block diagram of Fig.1. Their function can best be explained by describing how the instrument operates in its different modes.

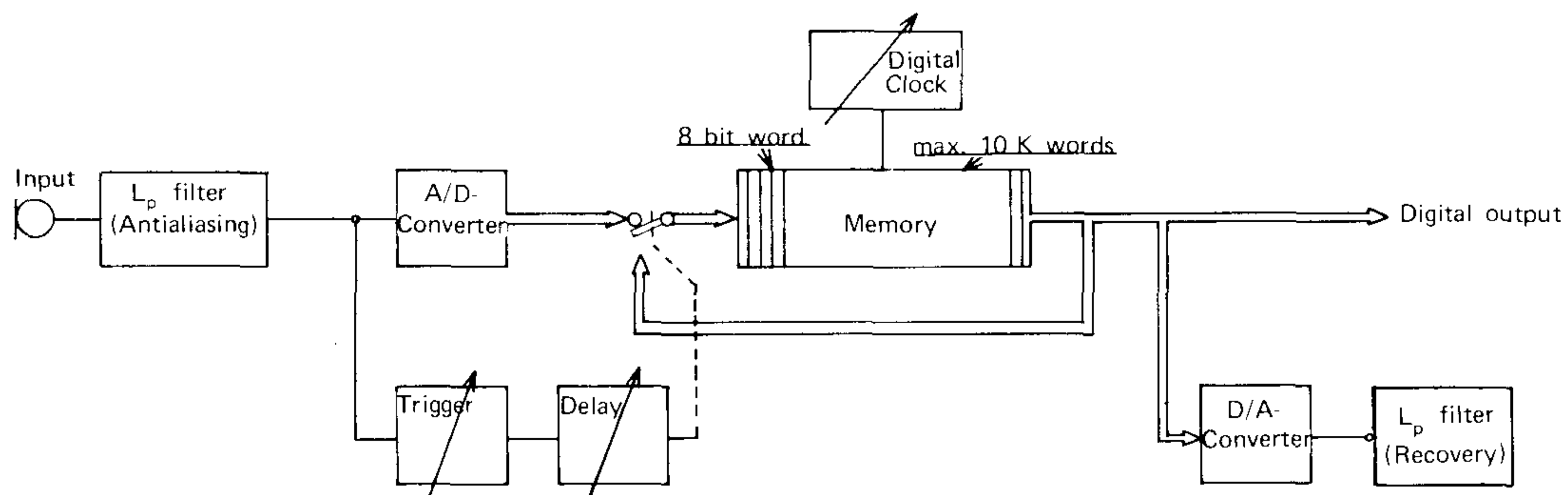

572096

Fig.1. Block diagram of the Digital Event Recorder

Recording

In the recording mode an electrical signal from the input is passed through a low pass filter to an analog to digital (A/D) converter which converts the varying amplitude of the input signal to a continuous series of digital numbers which are generated and transferred to the memory at the clock rate (sampling frequency). The digital numbers are transferred (by clock pulses) through all the memory positions until they appear at the output to be led either directly to other digital equipment or to the digital to analog (D/A) converter which changes the series of digital numbers to a varying analog signal. After the signal has passed a low pass filter (recovery filter) it resembles the input signal only delayed by the time determined by the number of memory positions, divided by the clock frequency.

The delay time also represents the sweep time, or in other words the time length for which a continuous record of the signal exists in the memory. As new information is being introduced at the clock rate and consequently old information is removed the recording must be stopped when the interesting part of a signal is fully contained in the memory. This is performed by the triggering circuit.

Triggering

The triggering circuit constantly monitors the input signal. When the preset triggering conditions are satisfied it emits a pulse which is passed over a variable delay to switch the input of the memory from the output of the A/D converter to its own output. Thereby the digital numbers contained in the memory are continuously rotated through the memory positions to form a record of one sweep time of the original signal. The setting of the variable delay determines which part of the signal is stored, ranging from the sweep time just prior to the triggering pulse up to a starting point of nine sweep times after the triggering pulse.

Play back

By rotating the signal information stored in the memory and activating the D/A converter an analog signal appears at the output. The signal is filtered by a low pass filter to eliminate high frequency switching transients due to the discrete point storing technique. The signal is reproduced with the same properties as the original signal if the clock frequency for play back equals the recording sampling frequency. By selecting different clock rates, linear frequency (and time) transformations are readily carried out to facilitate frequency analysis or recording on graphic recorders. The input sampling rate can be chosen from 100 to 100000 samples per second (or slower by an external generator). The output rate can be varied between 0.5 and 500000 samples per second.

The total memory content can be varied from the standard 4096 (4k) memory cells of 8 bit words up to 10k or down to 2k in 2k steps..

Sampling technique

The amplitude of the input signal to the Digital Event Recorder is sampled at discrete time intervals and the amplitude at each sampling point is transformed by the A/D converter to a digital number which can be stepped through the memory. The validity of this method builds on the "Sampling Theorem" (see the references) which states that a time function $f(t)$ can be completely determined by sampling the function at a rate which is at least twice the highest frequency contained in the signal. However, if higher frequencies than half the sampling frequency do exist disturbing "aliasing"

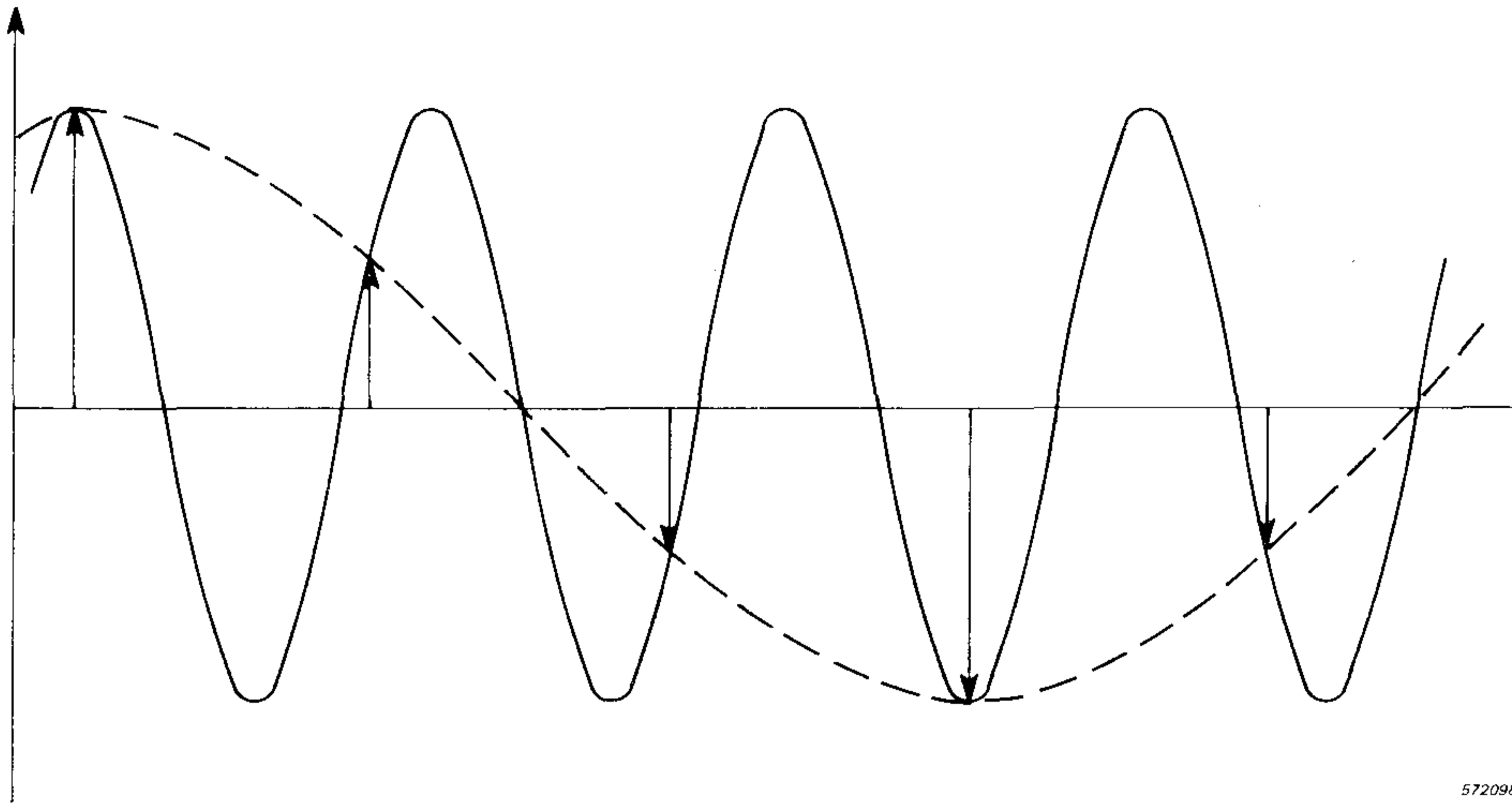

Fig.2. Example of aliasing effect

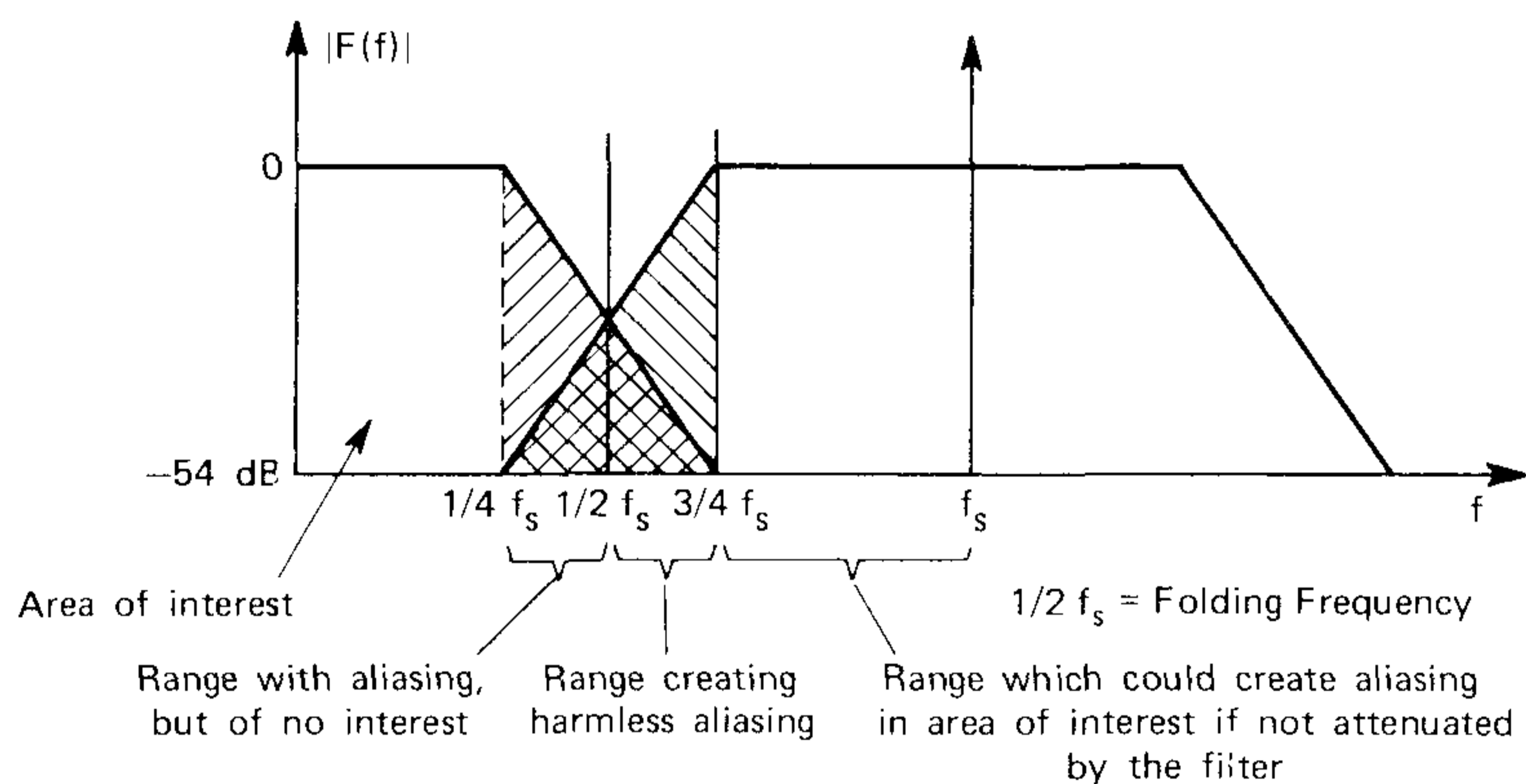
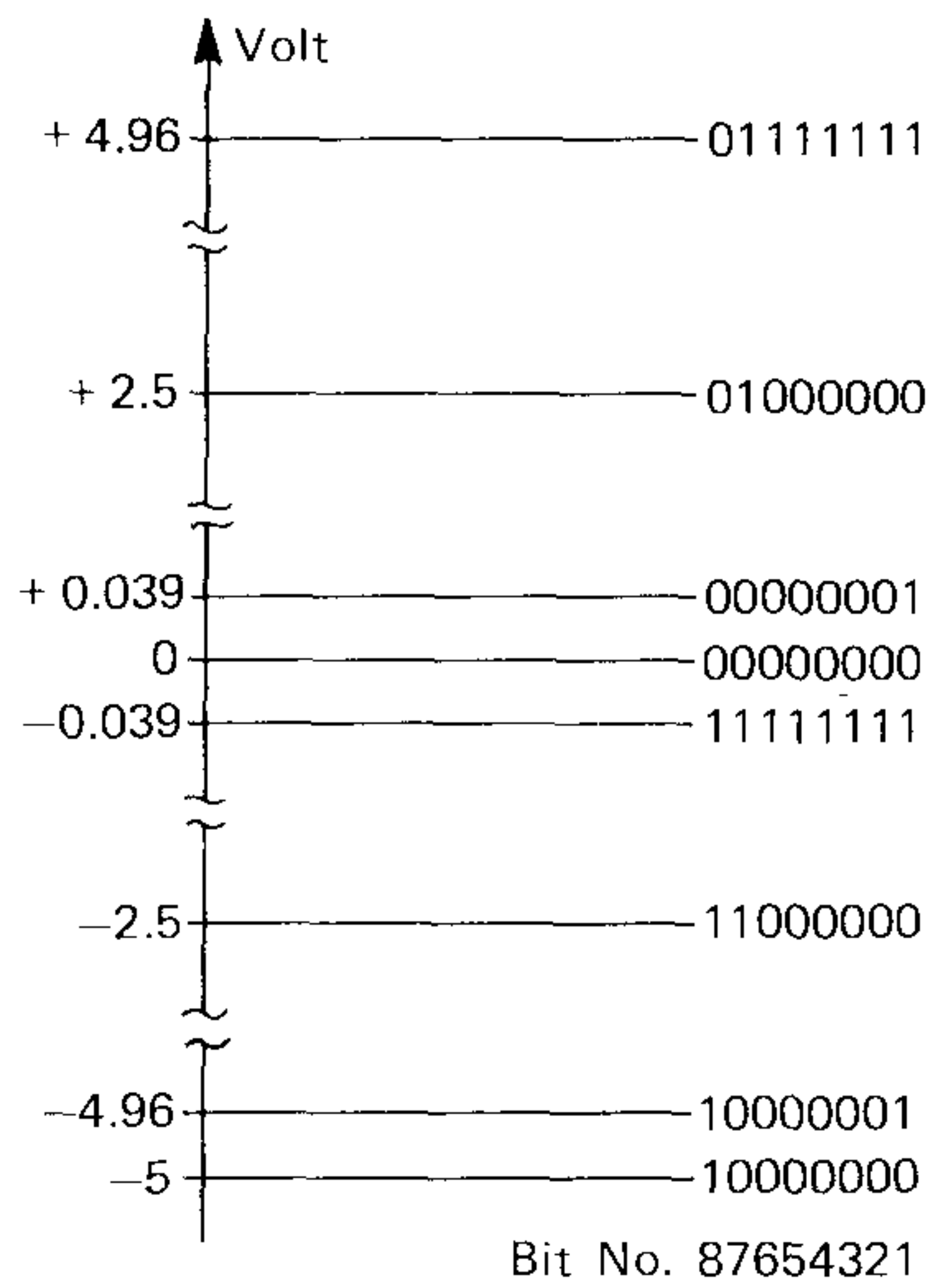

Fig.3. Diagram of frequency domain of interest for aliasing effects

phenomena would occur i.e. high frequency components would after sampling appear as false low frequency values. An example of this is illustrated in Fig.2 where the full line represents the real signal. The arrows represent the sampled points and the dashed line displays the apparent low frequency signal. To avoid such effects the useful frequency range of the Digital Event Recorder has been chosen to be one quarter of the sampling frequency and a low pass or antialiasing filter reduces the signal components over this frequency. This is illustrated in Fig.3 where it can be seen that the frequencies between $3/4 f_s$ and f_s which could produce aliasing effects are reduced by at least 54 dB. The full concept of sampling theory and the error functions involved is, however, too complicated to describe fully in this short description and the interested reader is referred to the references for further informations.



Bit 8 is the most significant bit (MSB) or the sign
 Bit 1 is the least significant bit (LSB)

272162

Fig.4. The digital quantizing of the amplitude range

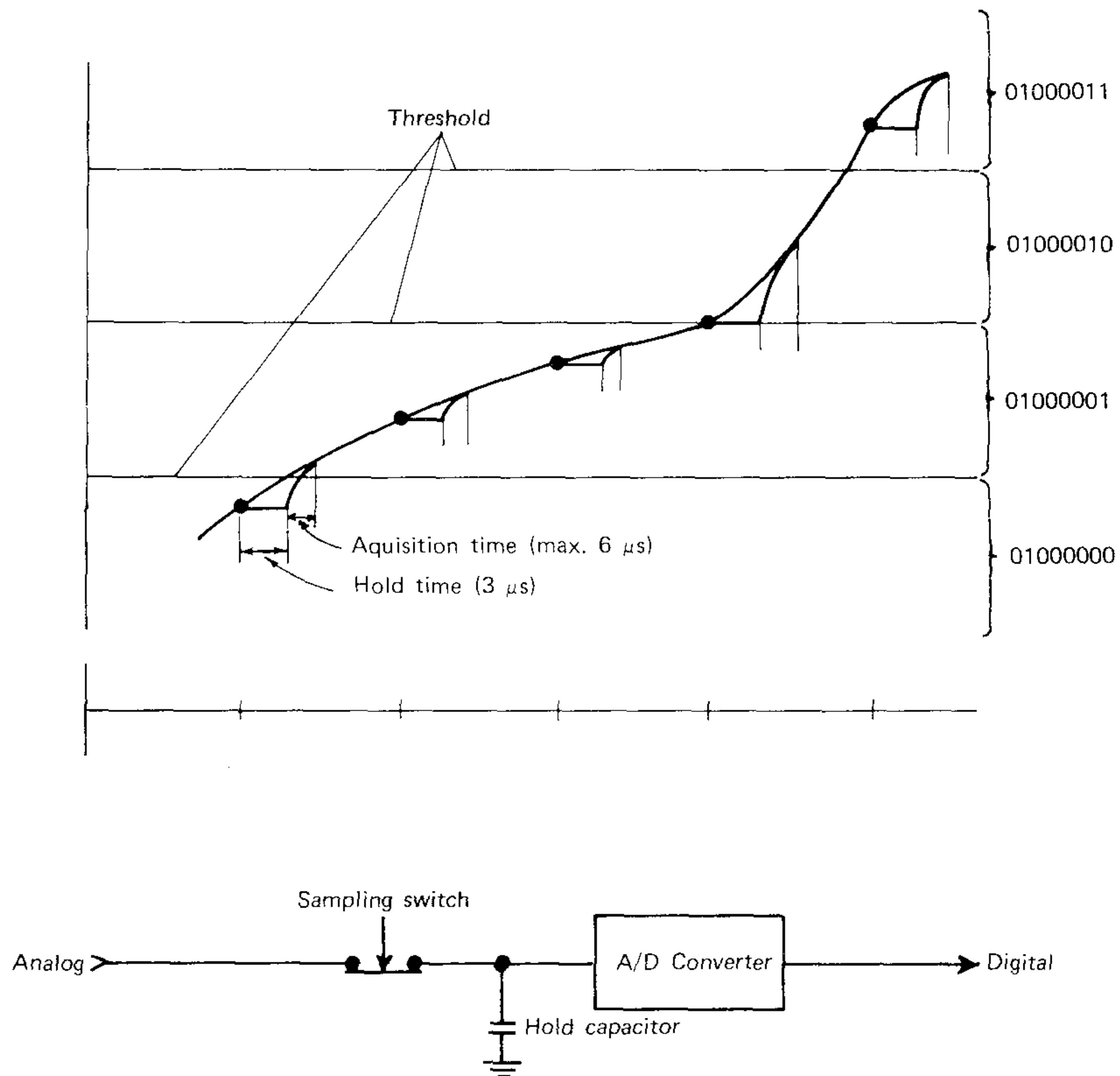

572097

Fig.5. Sample and hold operation of the A/D converter assembly

A/D conversion

As the amplitude values are stored as digital numbers the continuously varying input signal must be quantized. This is done by graduating the input level range of ± 5 Volts into 256 discrete steps of approximately 39 mV each. Each level is assigned a binary number as indicated in Fig.4 rendering 256 8 bit binary numbers. Positive values are assigned the numbers from 00000001 to 01111111 and negative values the numbers from 11111111 to 10000000 by assigning the 2's complement to the corresponding positive values (by inverting the positive number and adding one). The actual sampling procedure is carried out as shown in the circuit of Fig.5 where the hold capacitor voltage follows the input signal until the sampling switch opens by a clock pulse. The capacitor then holds a constant voltage (sampling value) while the A/D conversion is carried out.

Applications

The Digital Event Recorder has been used successfully for a number of different applications. The most obvious ones are, naturally, the capture and reproduction of mechanical or acoustic pulses, for subsequent frequency analysis on analog analyzers, or it can be used as an input device for signal analysis in digital computers. However, it has also proven useful to record slow varying signals and repeating them at higher speeds for convenient frequency analysis or observation purposes. Similarly it is possible to introduce artificial amplitude values manually or by digital means to the memory in order to produce complicated pulses. Presently the device is used in some experiments where sample parts of steady state signals are analysed at high speed.

References:

- | | |
|---|---|
| JOHN C. HANCOCK: | The Principles of Communication Theory
Mc. Graw Hill, 1961. |
| FLEMMING MADSEN and
HENNING STRÅRUP: | Sampling and Quantizing Technique in
relation to the Digital Event Recorder
Type 7502. Brüel & Kjær, Application
Note. |

Determination of the Radii of Nodal Circles on a Circular Metal Plate

by

F.W. Ravenhall and A.K. Som)*

ABSTRACT

This paper describes a method for determining the radii of nodal circles which are produced when a freely-suspended circular metal plate vibrates in its circular modes. The plate is excited using a vibration generator in direct physical contact, and the positions of the nodal points are located with the aid of a magnetic vibration detector. The results are subsequently compared with those obtained from another source.

SOMMAIRE

L'article décrit une méthode permettant de déterminer les rayons des cercles nodaux produits lorsqu'une plaque métallique circulaire librement suspendue vibre en mode circulaire. La plaque est excitée par un générateur de vibrations en contact physique direct, et les positions des points nodaux sont déterminées à l'aide d'un détecteur de vibrations magnétique. Les résultats sont ensuite comparés à ceux obtenus d'une autre source.

ZUSAMMENFASSUNG

Dieser Artikel beschreibt eine Methode zur Bestimmung der Knotenkreisradien, welche auftreten, wenn eine freischwebend aufgehängte runde Metallplatte in ihren Zirkular-Eigenschwingungen vibriert. Der Meßaufbau wird erklärt, wobei die Platte mit einem Schwingerreger direkt angeregt wird. Die Abstände der einzelnen Knotenpunktkreise vom Mittelpunkt der Platte werden mit einem magnetischen Schwingungswandler ermittelt und die erhaltenen Ergebnisse mit Werten, die nach einer anderen Methode erhalten wurden, verglichen.

Introduction

Various methods have been used in order to determine the positions of nodal lines produced when a metal plate vibrates at one of its natural frequencies. The most common method is to utilise Chladni's patterns, which are formed when sand grains are sprinkled onto the vibrating surface of the plate. The sand grains are caused to move to certain regions which are stationary and thus nodal lines are formed which depict the patterns. For

*) Physics Department, University of Malawi.

the circular plate used in these tests, those modes of vibration which produced nodal circles were used because of their suitability to the method chosen. It is normal when using this particular technique to use a plate that has previously been marked with graduated lines to assist in location measurements. However, this is not necessary here because the measuring transducer automatically detects the positions of minimum vibration.

Experimental Technique

In this experiment a circular steel plate was used having a diameter of 30.48 cm and a thickness of 0.157 cm. A Brüel & Kjær type MM 0002 magnetic transducer was used as a velocity sensitive vibration pick-up.

The transducer is a variable reluctance (moving iron) device, the moving iron part in this test being the steel plate itself. The voltage output from the transducer was fed directly to the 2113 audio frequency spectrometer for amplification and subsequent display. The transducer was mounted on a travelling microscope base so that its position could be accurately monitored relative to the surface of the plate. A diagram of the apparatus may be seen in Figure 1.

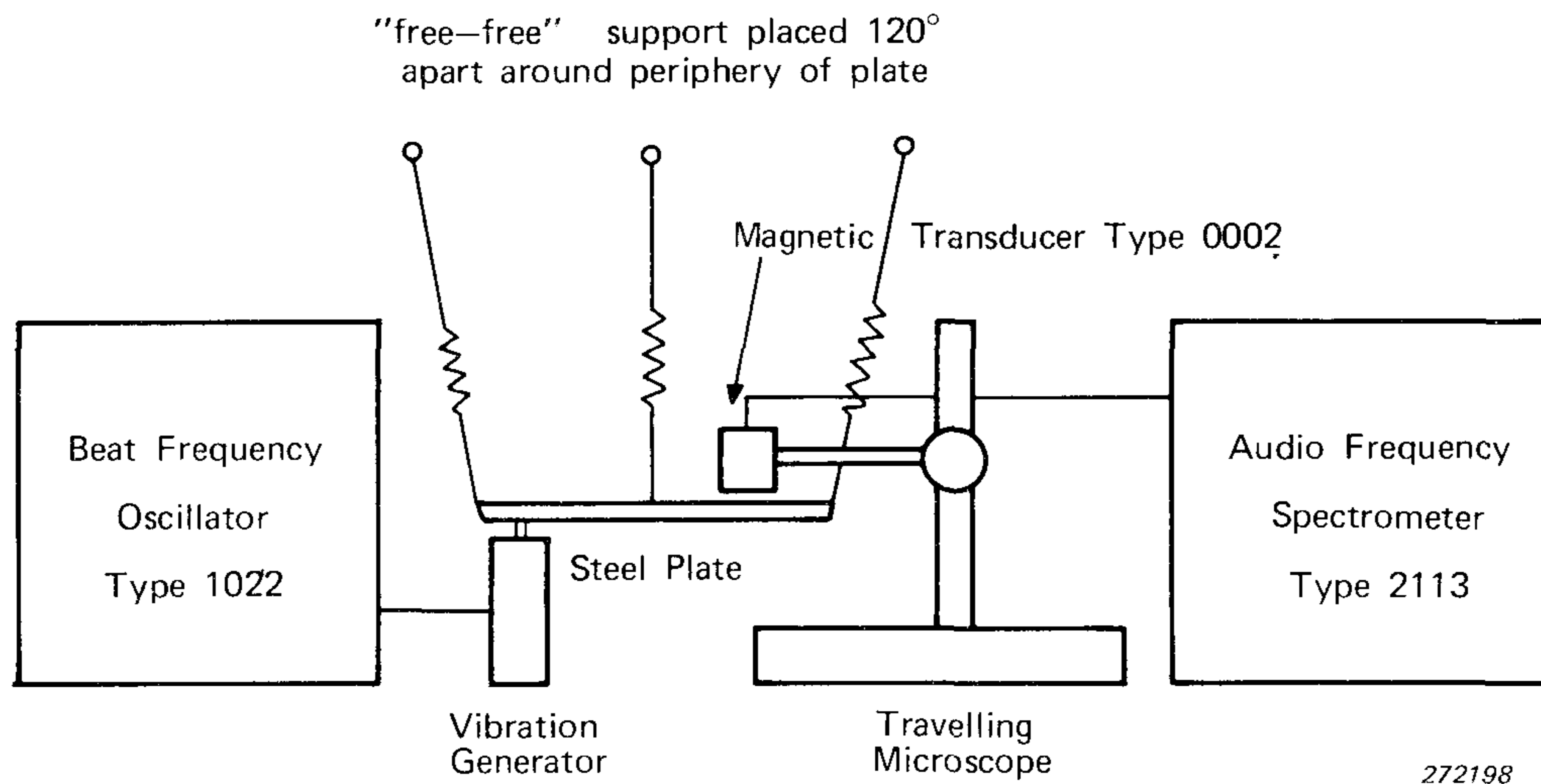

Fig.1. Measurement arrangement

The steel plate was suspended horizontally from elastic bands to ensure a "free-free" support (Ref.1) and the transducer mounted over its centre in such a way that the vernier on the travelling microscope read 0 cm. The height of the transducer head above plate surface was fixed at 5 mm.

The transducer could now be moved along a radius of the plate parallel to the plate's surface and its movements accurately measured. The plate was

then set into steady state vibration using the vibration generator which was fed from the beat frequency oscillator, Type 1022.

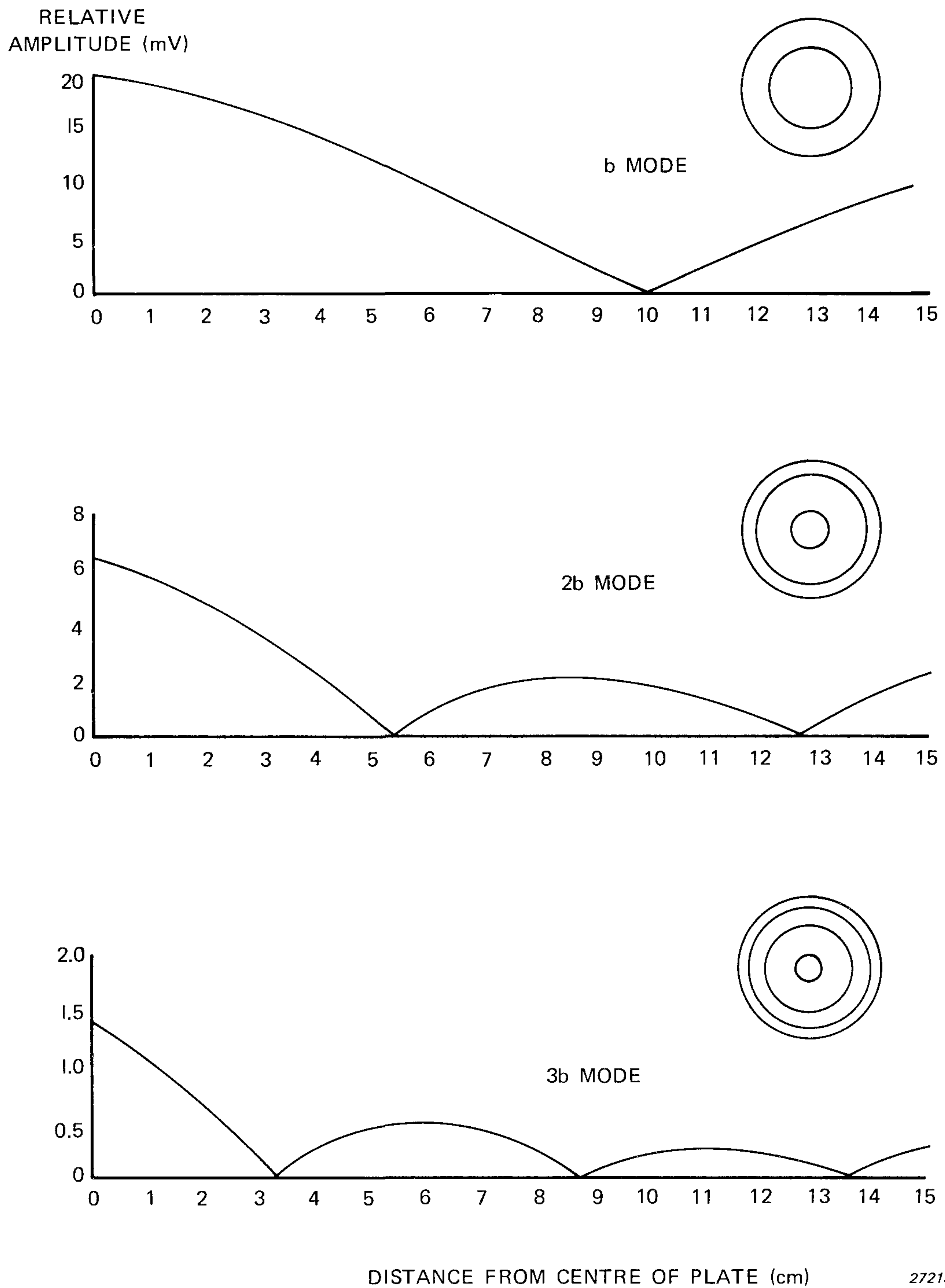

Fig.2. Graphs showing positions of modes

The frequency on the beat frequency oscillator was set at 156 Hz, which is the known first circular (b) mode for the steel plate.

The transducer was then moved outwards across the surface of the vibrating plate in 1 cm steps; the output from the transducer was noted on the dial of the audio frequency spectrometer, whose filter centre frequency was set to pass the signal.

The procedure was then repeated for the (2 b) and (3 b) modes of vibration. Graphs were then plotted (see Figure 2) of the relative amplitude in mV against distance from the centre of the plate in cm, and the nodes (i.e. positions of zero amplitude) obtained from them.

Results

The measured values are tabellized below.

Mode	Plate Vibration Frequency	Filter Centre Frequency
b	156 Hz	160 Hz
2b	634 Hz	630 Hz
3b	1438 Hz	1600 Hz

Distance of transducer from centre of plate cm	Relative amplitude (mV) (velocity signal)		
	b Mode	2b Mode	3b Mode
0	20.00	6.40	1.40
1	19.25	5.80	1.05
2	18.10	4.80	0.59
3	16.10	3.50	0.124
4	14.40	2.04	0.26
5	12.10	0.64	0.48
6	9.75	0.57	0.50
7	7.41	1.47	0.36
8	5.00	2.00	0.137
9	2.56	2.15	0.086
10	0.18	1.90	0.244
11	2.25	1.35	0.286
12	4.60	0.52	0.215
13	6.80	0.43	0.063
14	8.80	1.40	0.125
14.5	9.85	1.90	0.216

From Figure 2 the positions of zero amplitude (nodes) are:

- b mode (1 circular ring) 0 mV at 10.1 cm
- 2b mode (2 circular rings) 0 mV at 5.51 cm and 12.6 cm
- 3b mode (3 circular rings) 0 mV at 3.3 cm, 8.6 cm and 13.4 cm

The above figures were checked with the transducer head positioned over the respective points on the plate, and zero output was registered.

Now if R_d = radius of plate = 15.24 cm

	R_n	=	radius of nodal circle (cm)	
b Mode	$\frac{R_n}{R_d}$	=	0.662 (0.680)	
2b Mode	$\frac{R_n}{R_d}$	=	0.363 (0.391)	1st circle
	$\frac{R_n}{R_d}$	=	0.830 (0.843)	2nd circle
3b Mode	$\frac{R_n}{R_d}$	=	0.216 (0.257)	1st circle
	$\frac{R_n}{R_d}$	=	0.564 (0.591)	2nd circle
	$\frac{R_n}{R_d}$	=	0.880 (0.895)	3rd circle

(figures in brackets due to Waller, Ref. 2)

Conclusion

It can be seen that the figures obtained from the test agree fairly closely with those due to Waller. As the transducer head has a diameter of 15 mm, it is probable that the slight discrepancies arose because of the difficulty of positioning the exact centre of the head above the nodal points on the plate. Results of greater accuracy could be obtained by the use of one of the range

of transducers introduced by Brüel & Kjær which are designed to eliminate the ambiguity of position measurement.*)

References

1. MASON, J.M. and LEVENTHALL, M.G. The Efficiency of Various "free-free" Support Systems for a Flexing Beam. *Acoustica* Vol. 23, No. 6, 1970.
2. WALLER, MARY D. Chladni Figures – a Study in Symmetry. Bell & Sons, London, 1961.

*) For example a probe microphone as used by Blay et al., Technical Review No. 4, 1971. Editors note.

Brief Communications

The intention of this section in the B & K Technical Reviews is to cover more practical aspects of the use of Brüel & Kjær instruments. It is meant to be an "open forum" for communication between the readers of the Review and our development and application laboratories. We therefore invite you to contribute to this communication whenever you have solved a measurement problem that you think may be of general interest to users of B & K equipment. The only restriction to contributions is that they should be as short as possible and preferably no longer than 3 typewritten pages (A4).

New Protractor For Reverberation Time Measurements

by

Alberto Behar and Jorge Menyhart)*

Introduction

Determination of absorption coefficients of materials as well as Reverberation Time measurements are often carried out utilizing the sound level decay rate method. Since, the decay time is hardly ever measured down to 60 dB (defined for Reverberation Time) one resorts to approximating a part of the curve to a straight line (generally 30 – 40 dB) and determining the slope of the curve and the paper speed of the level recorder. The slope, however, also depends on the potentiometer range used in the level recorder. The Brüel & Kjær protractor makes the measurement possible for four combinations of potentiometer range and paper speed: 50 dB and 10 mm/s, 30 dB and 30 mm/s, 75 dB and 10 mm/s and 75 dB and 30 mm/s. The most widely used combination is the first one as it utilizes less paper, and 50 dB potentiometer gives better visualisation.

To facilitate evaluations of the slope of the decay curve when several measurements are taken, a new protractor has been designed at the acoustic laboratory in the faculty of architecture of the University of Buenos Aires.

*) University of Buenos Aires.

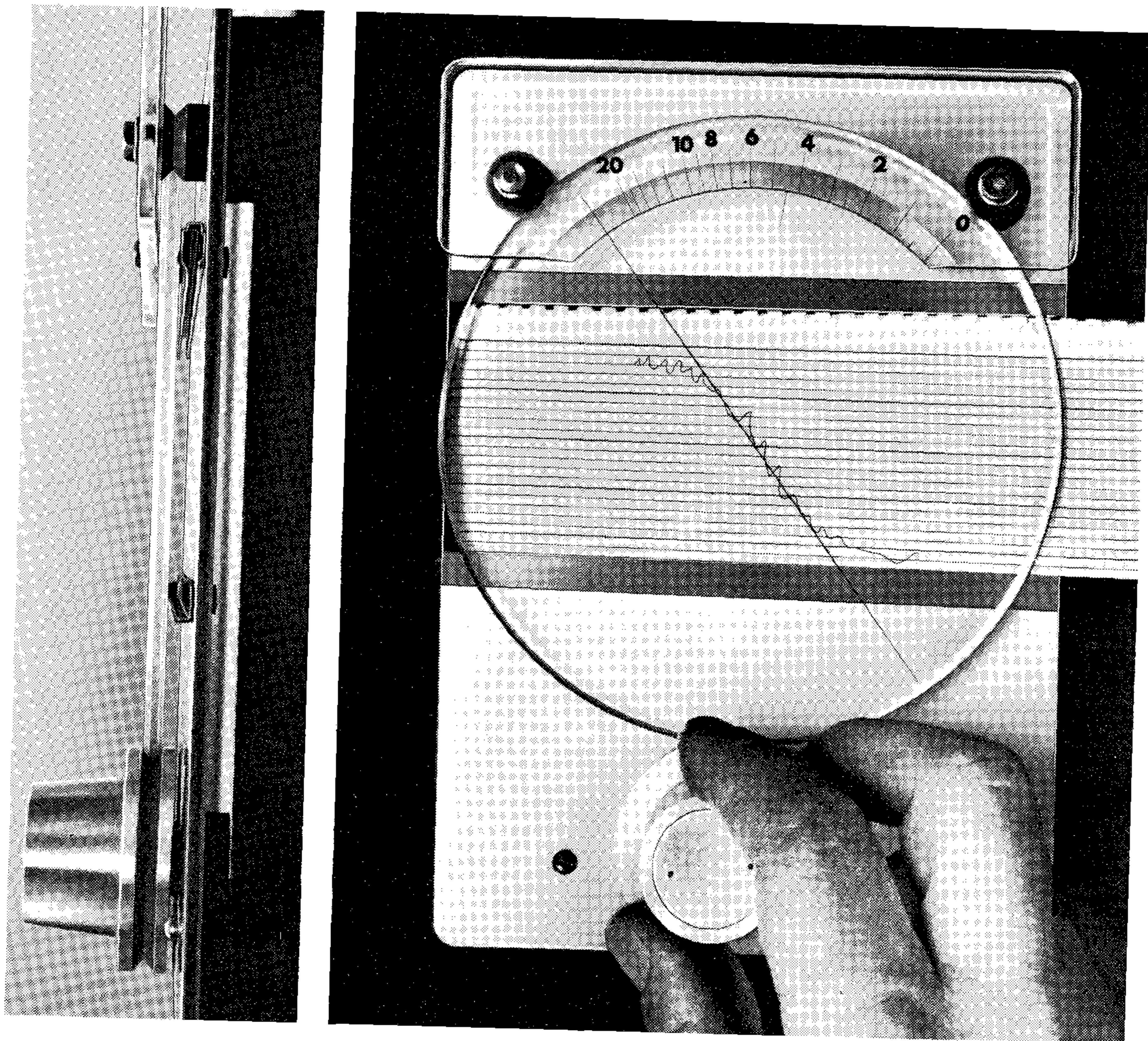

Fig.1. New Protractor

Description

The new protractor shown in Fig.1 consists of a movable disc with a diametral line drawn on it to linearize the slope. Another short reference line serves as a pointer for the fixed scale graduated in time units. Underneath the disc the paper is placed between two guides which ensures that it is held in a constant position relative to the disc. On turning the disc. the diametral line is made coincident with the decay curve whereupon the reference line will indicate the reverberation time on the fixed scale.

Although this protractor can only be used for the combination of potentiometer range 50 dB and paper speed 10 mm/s, other combinations can be used by merely interchanging the graduated scale. When waxed paper is used a plexiglass sheet can be placed under the paper and illuminated from the side. The light rays guided by the plexiglass will shine through it onto the paper illuminating the curves.

Details of construction

The base of the protractor is made from an aluminium sheet of dimensions 18.5 x 13 x 0.3 cm. A transparent acrylic disc 13 cm in diameter and 0.3 cm thick having 45° bevelled edges is held by three V shaped pulleys, two of which are made from acryl and are 1 cm in diameter and act as rotating bearings. The third pulley which serves as a knob for turning the disc is made of aluminium, 4.5 cm in diameter and has an ebonite base which increases the friction between it and the disc. The fixed scale which is also made of transparent acryl is supported 0.5 mm above the disc by two brass supports attached to the aluminium base which also serve as axes for the two small pulleys.

From Fig.2 the decay rate is seen to be

$$\Delta = \frac{N}{t}$$

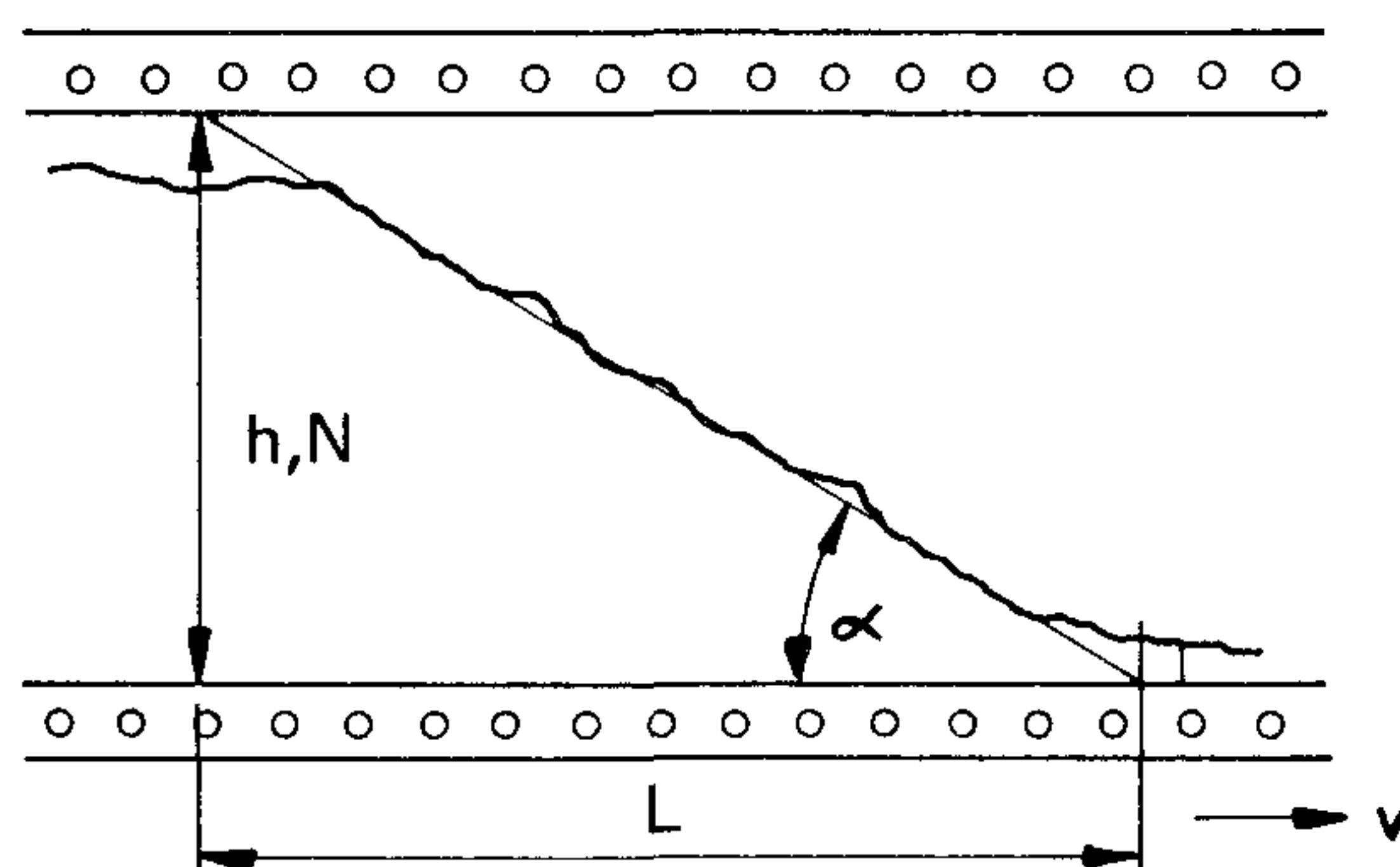
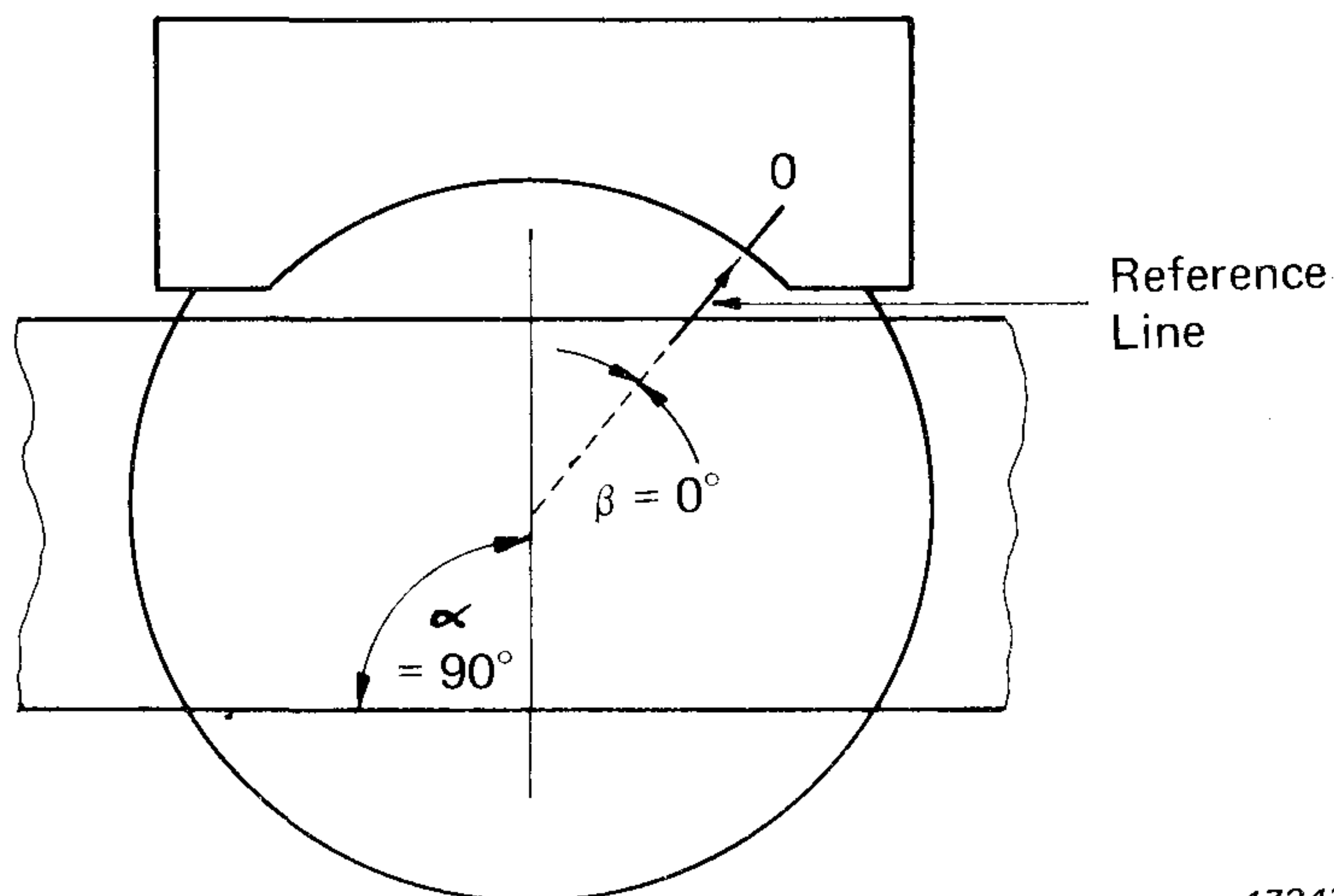

Fig.2. Decay Curve

where N is the dynamic range of the paper
and t is the time taken by the paper to move a distance L .

From the definition of reverberation time T as $T = \frac{60}{\Delta}$ we obtain

$$T = \frac{60t}{N} \quad (1)$$



172435

Fig.3. Position of Reference Line and 0 Reverberation Time

From Fig.2

$$t = \frac{L}{V} \quad \text{where } V \text{ is the paper speed}$$

and $L = \frac{h}{\tan \alpha}$ where h is the paper width

Substituting in (1) we obtain

$$T = \frac{60 h}{N V \tan \alpha}$$

i.e. $\alpha = \tan^{-1} \left(\frac{60 h}{N.T.V} \right)$ (2)

For the case when one uses a 50,dB potentiometer, 50 mm paper width and paper speed 10 mm/s one obtains

$$\alpha = \tan^{-1} \left(\frac{6}{T} \right)$$
 (3)

In Fig.3 the disc is turned until the diametral line is vertical and the reference line is marked on the disc corresponding to the zero reverberation time mark on the fixed scale. The other markings of the reverberation time on the fixed scale are obtained by determining the angle β shown in Fig.4. For each reverberation time the angle α can be determined from eq. 3 and since $(\alpha + \beta) = 90^\circ$, β can be obtained for the corresponding reverberation times. By measuring angle β from zero reverberation time the corresponding reverberation times can be marked off on the fixed scale.

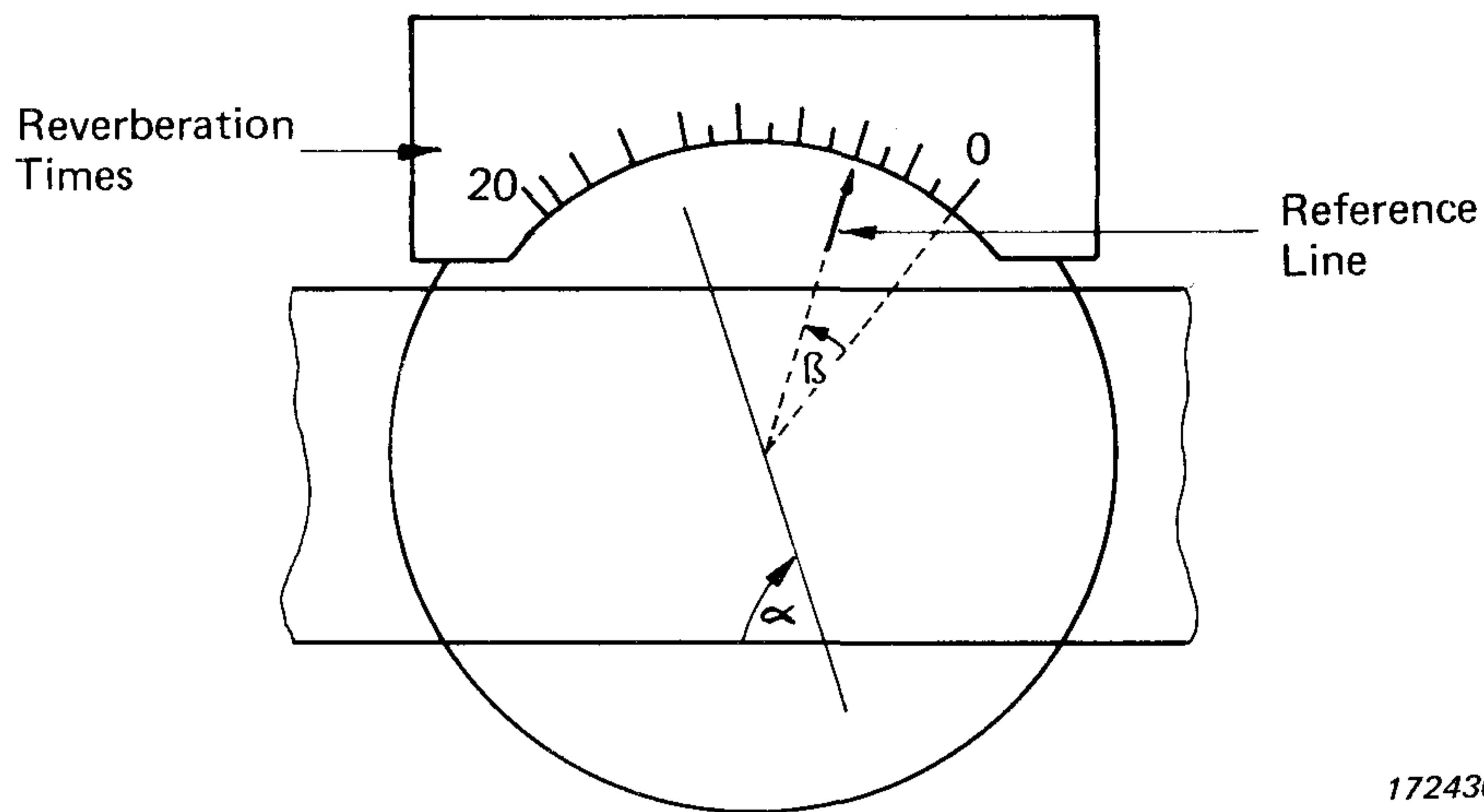

172436

Fig.4. Angle β corresponding to reverberation times

If, for example, the reference line was marked at an angle of 45° from the diametral line, the mark for reverberation time of 6 seconds on the fixed scale would be exactly vertically above the centre of the disc.

At present our laboratory is working on the study of different types of signals used in reverberation time measurements. Since several measurements have to be taken and reverberation times evaluated, the use of this protractor has saved considerable amount of time. It is, therefore, deemed that such a protractor would be useful in other laboratories engaged in similar tasks.

News from the factory

Frequency Analyzer Type 2120

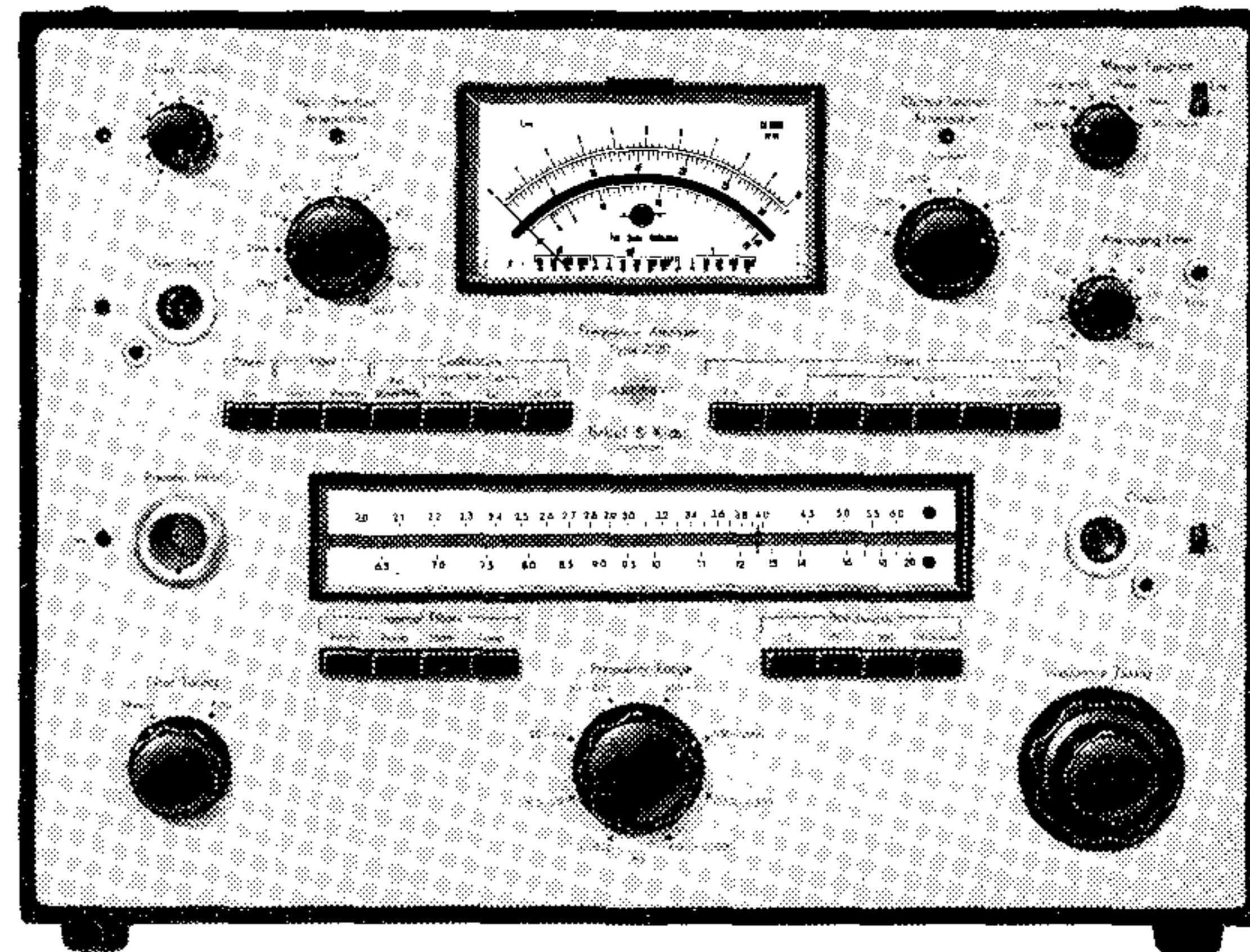

The Frequency Analyzer Type 2120 (selective frequency range 2 Hz – 20 kHz) is a combination of the Measuring Amplifier Type 2607 and an active, continuously variable RC filter complex which can be used in four basic modes.

1. As a constant percentage bandwidth analyzer having four selectable bandwidths, 1%, 3%, 10% and 1/3 octave.
2. As a tunable bandstop filter which will suppress a single frequency more than 60 dB, suppression at $0.5 f_0$ and $2 f_0$ is less than 1 dB. The bandstop mode can be used for distortion measurements down to a level of 1%.
3. As a tunable high pass filter and
4. as a tunable low pass filter.

The internationally standardized A, B and C weighting networks for sound measurements are included as well as the proposed D weighting network.

Provision is made for the connection of external filters to be used alone or in series with one of the internal filters. Utilizing for example the bandpass 1/3 octave Filter Set Type 1614 the selective frequency range can be extended to 180 kHz.

An account of the low noise level of $0.4 \mu\text{V}$ and a measuring range (10 μV to 30 V RMS) the Analyzer is ideal for shock and vibration analysis over a wide dynamic and frequency range. For measurement of short duration shocks ($> 20 \mu\text{s}$) the peak indication is extremely useful.

When the analyzer is used with a Level Recorder Type 2305 or 2307 a continuous frequency sweeping analysis can be carried out and an automatic recording of noise and vibration spectrograms obtained. The analyzer in combination with one of the B & K microphones and preamplifier would perform both as a Precision Sound Level Meter according to ISO Recommendation 179 and as a Impulse Precision Sound Level Meter according to the proposed IEC Recommendation. Also they conform to the German DIN 45633 parts 1 and 2.

PREVIOUSLY ISSUED NUMBERS OF BRÜEL & KJÆR TECHNICAL REVIEW

(Continued from cover page 2)

- 3-1969 Frequency Analysis of Single Pulses.
- 2-1969 The Free Field and Pressure Calibration of Condenser Microphones using Electrostatic Actuator.
Long Term Stability of Condenser Microphones.
The Free Field Calibration of a Sound Level Meter.
Accelerometer Configurations.
Vibration Monitoring and Warning Systems.
- 1-1969 The Use of Digital Systems in Acoustical Measurements.
Impulse Noise Measurements.
Low Frequency Measurements Using Capacitive Transducers.
Details in the Construction of a Piezo-electric Microphone.
A New Method in Stroboscopy.
- 4-1968 On the Damaging Effects of Vibration.
Cross Spectral Density Measurements with Brüel & Kjær Instruments. (Part II).
- 3-1968 On the Measurement and Interpretation of Cross-Power-Spectra.
Cross Power Spectral Density Measurements with Brüel & Kjær Instruments (Part 1).
- 2-1968 The Anechoic Chambers at the Technical University of Denmark.
- 1-1968 Peak Distribution Effects in Random Load Fatigue.
- 4-1967 Changing the Noise Spectrum of Pulse Jet Engines.
On the Averaging Time of Level Recorders.
- 3-1967 Vibration Testing – The Reasons and the Means.

SPECIAL TECHNICAL LITERATURE

As shown on the back cover page Brüel & Kjær publish a variety of technical literature which can be obtained free of charge.

The following literature is presently available:

Mechanical Vibration and Shock Measurements

(English, German)

Acoustic Noise Measurements (English), 2. edition

Architectural Acoustics (English)

Power Spectral Density Measurements and Frequency Analysis
(English)

Standards, formulae and charts (English)

Instruction manuals (English, some available in German,
French, Russian)

Catalogs (several languages)

Product Data Sheets (English, German, French, Russian)

Furthermore, back copies of the Technical Review can be supplied as shown in the list above. Older issues may be obtained provided they are still in stock.

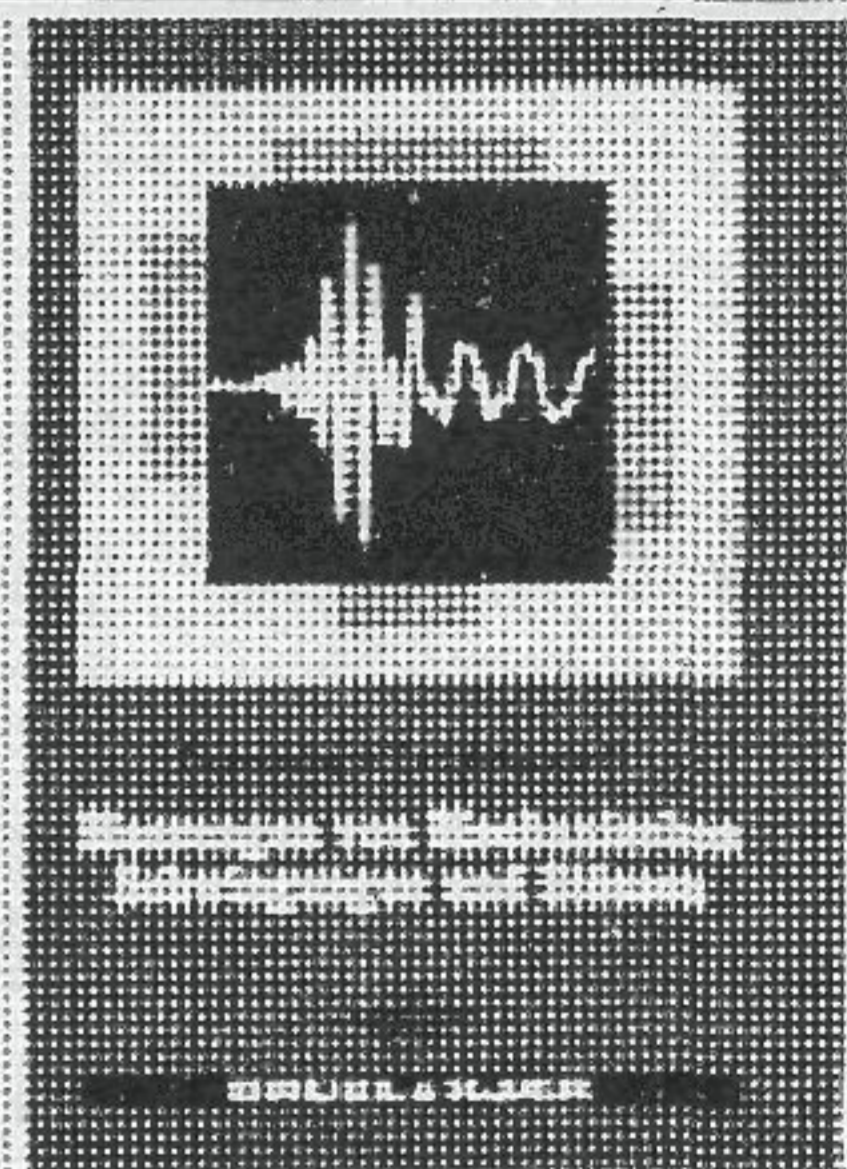
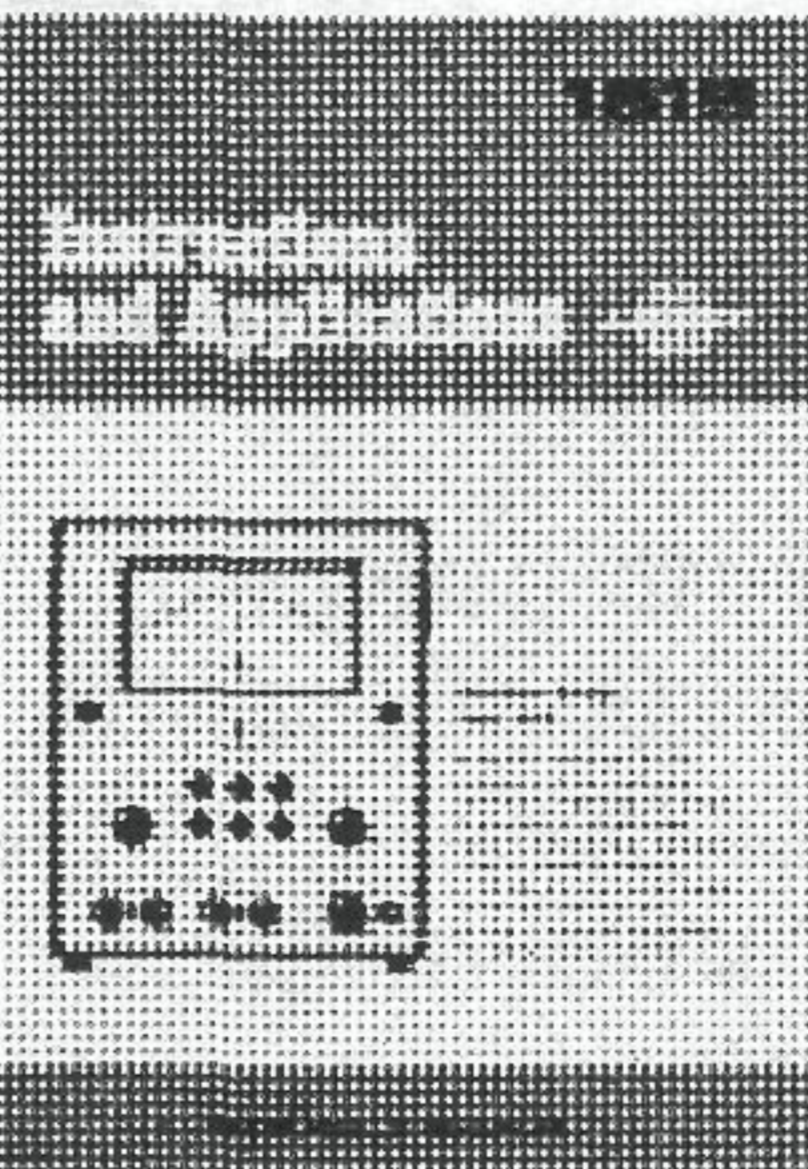
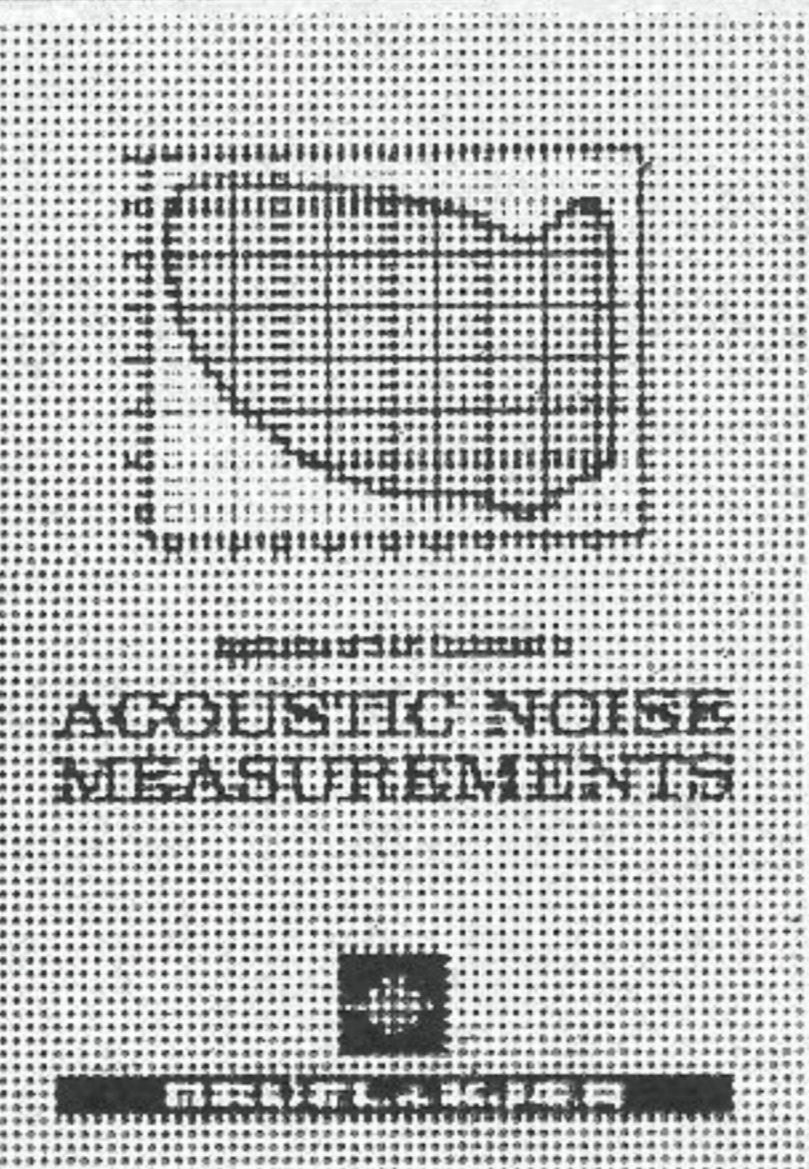
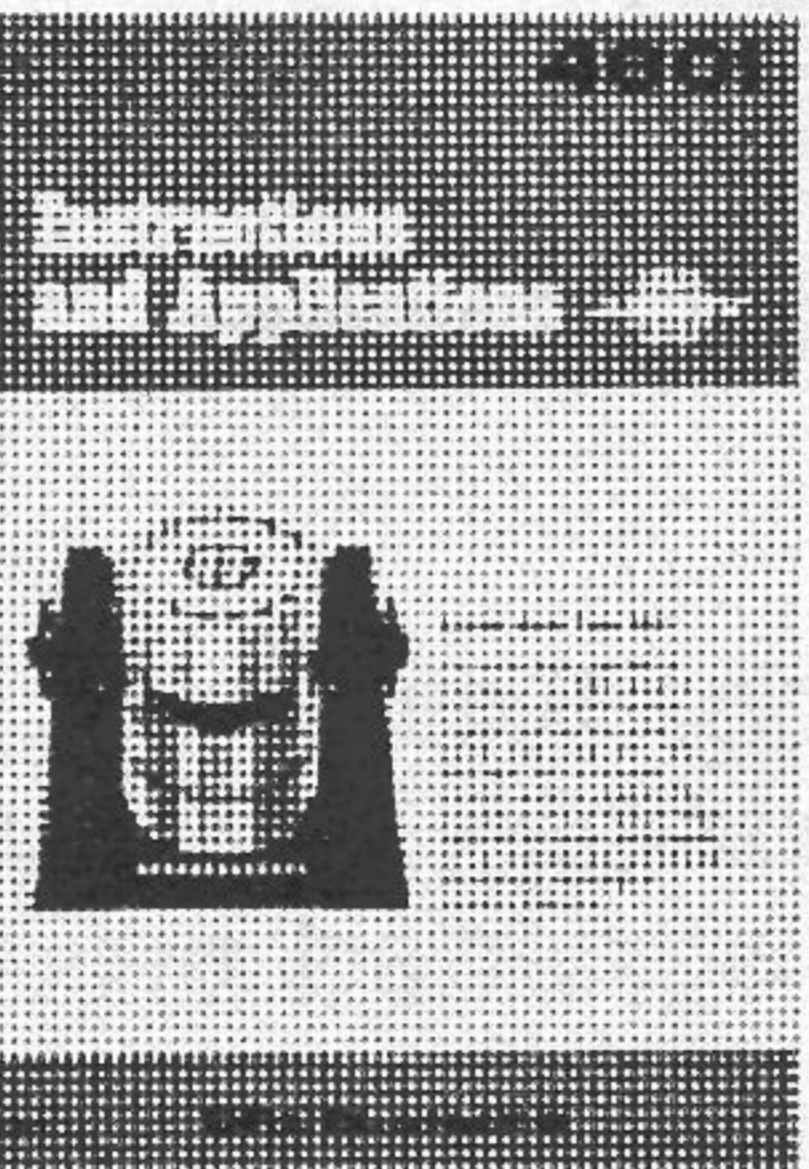
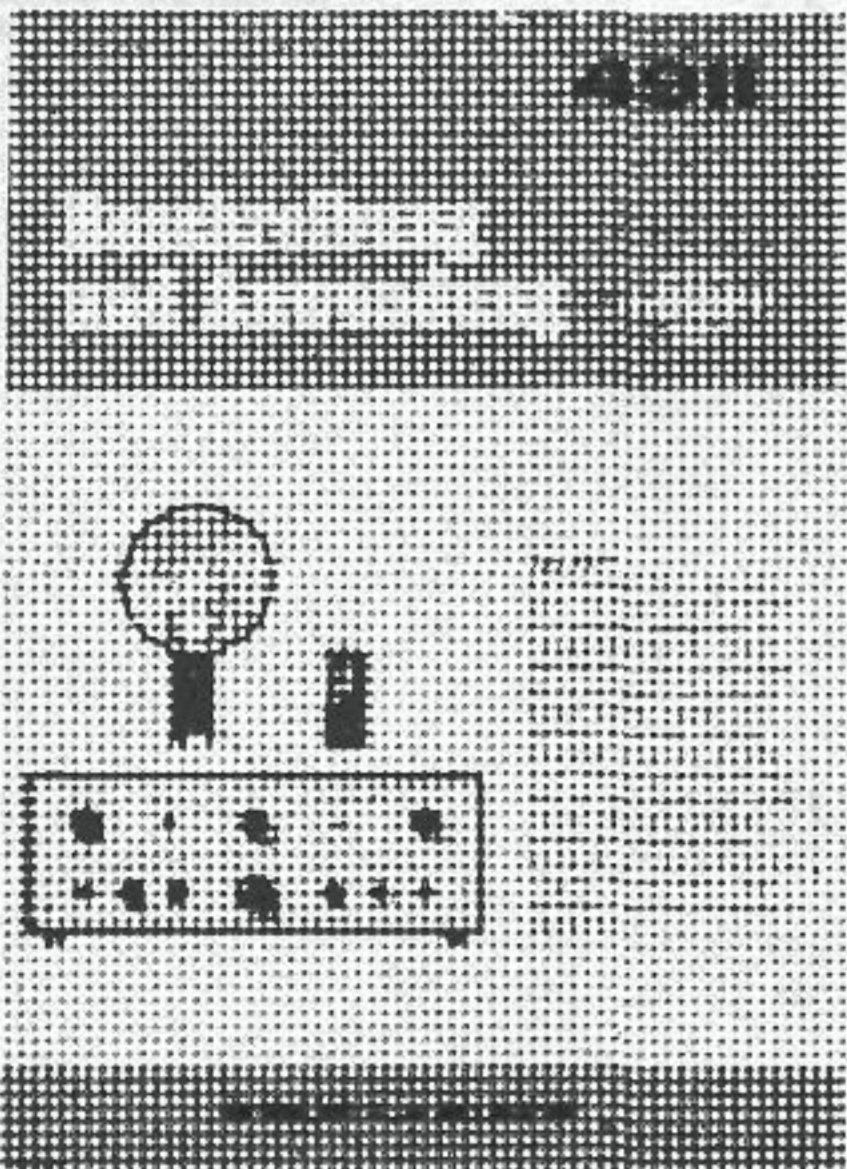
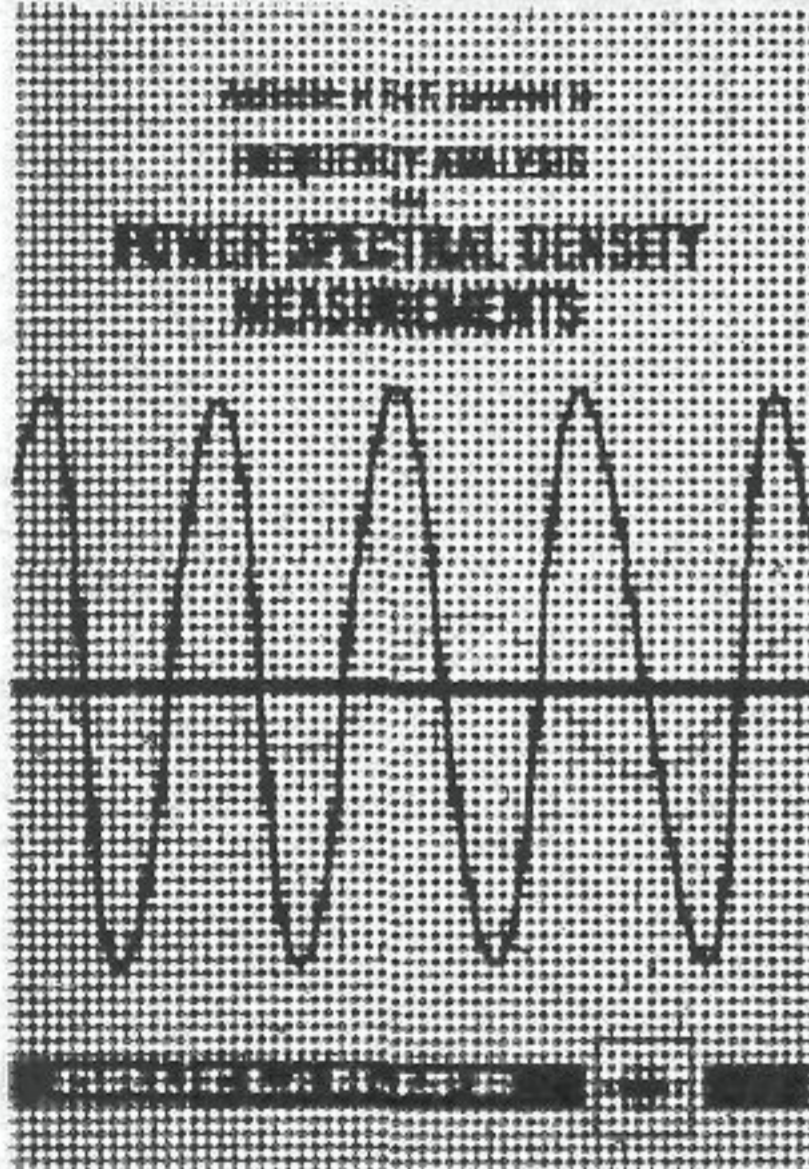
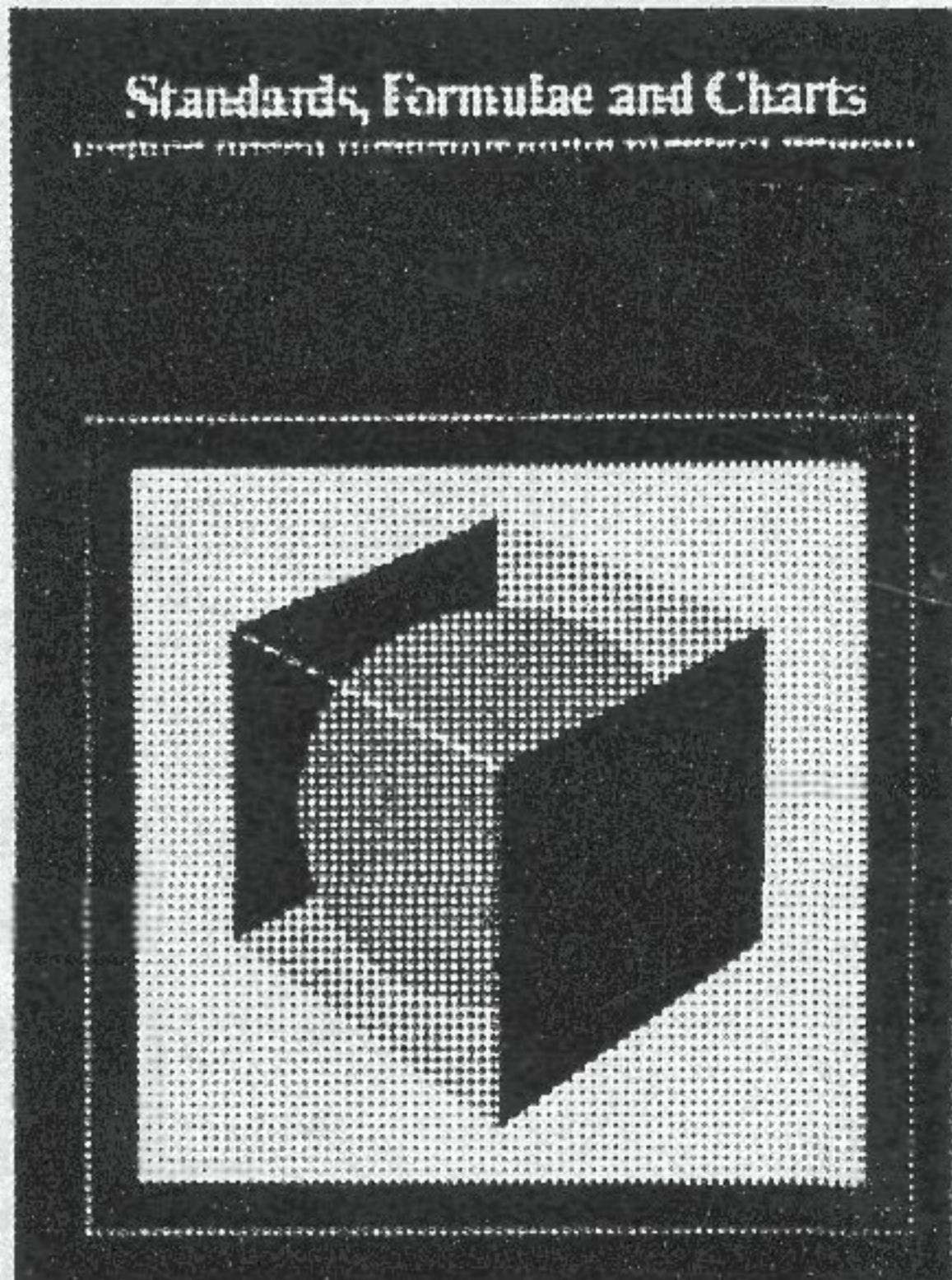
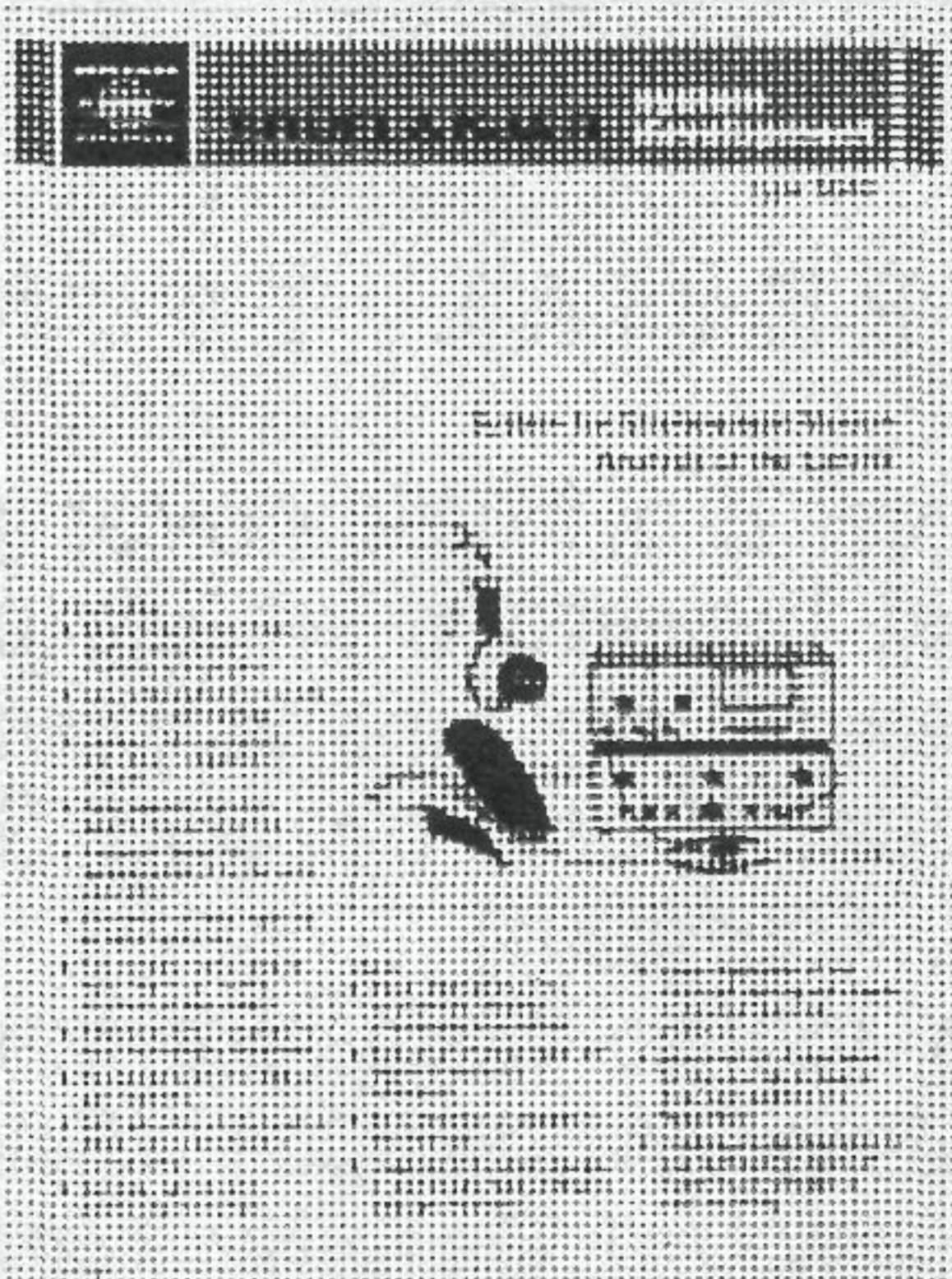
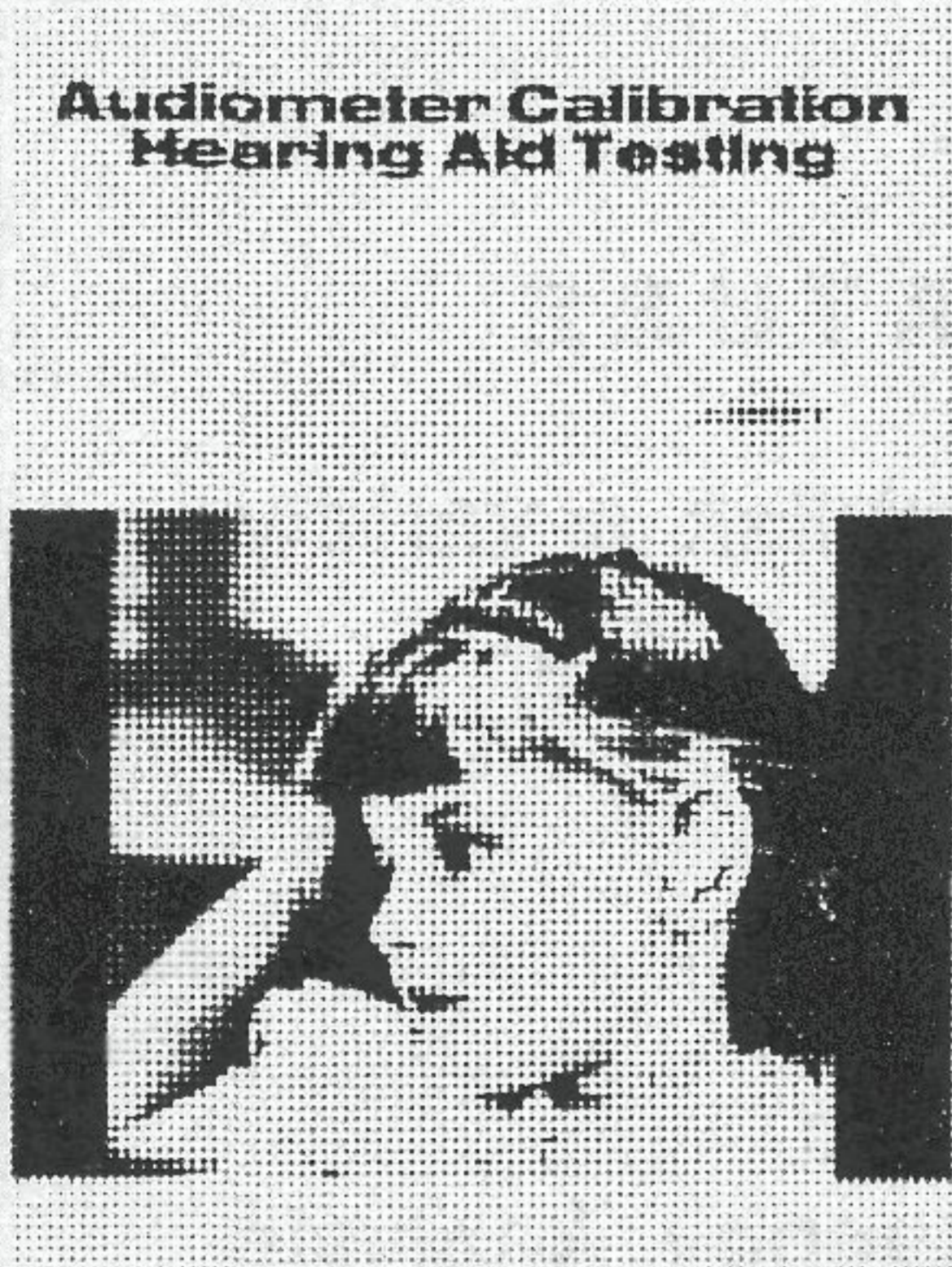
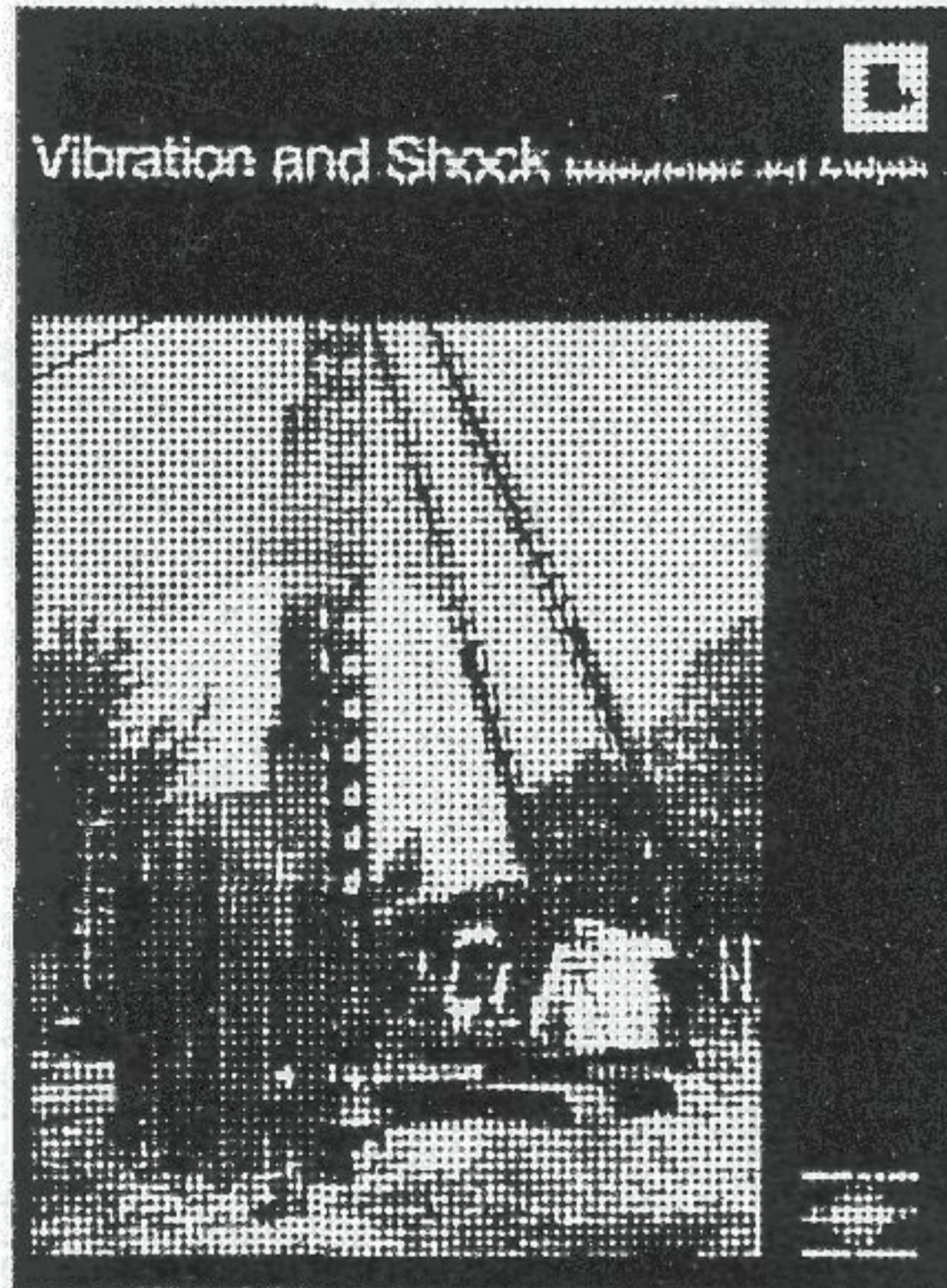
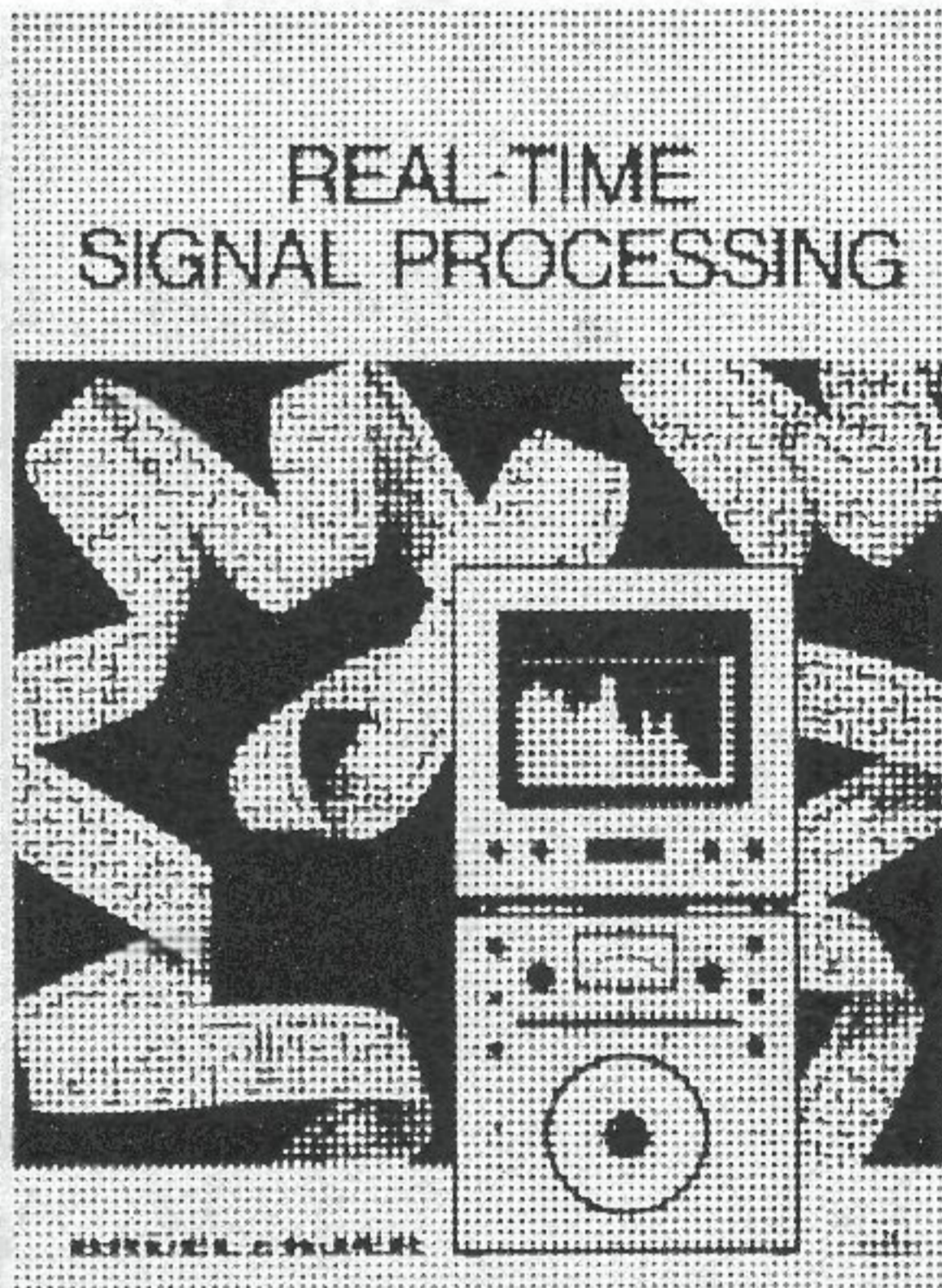
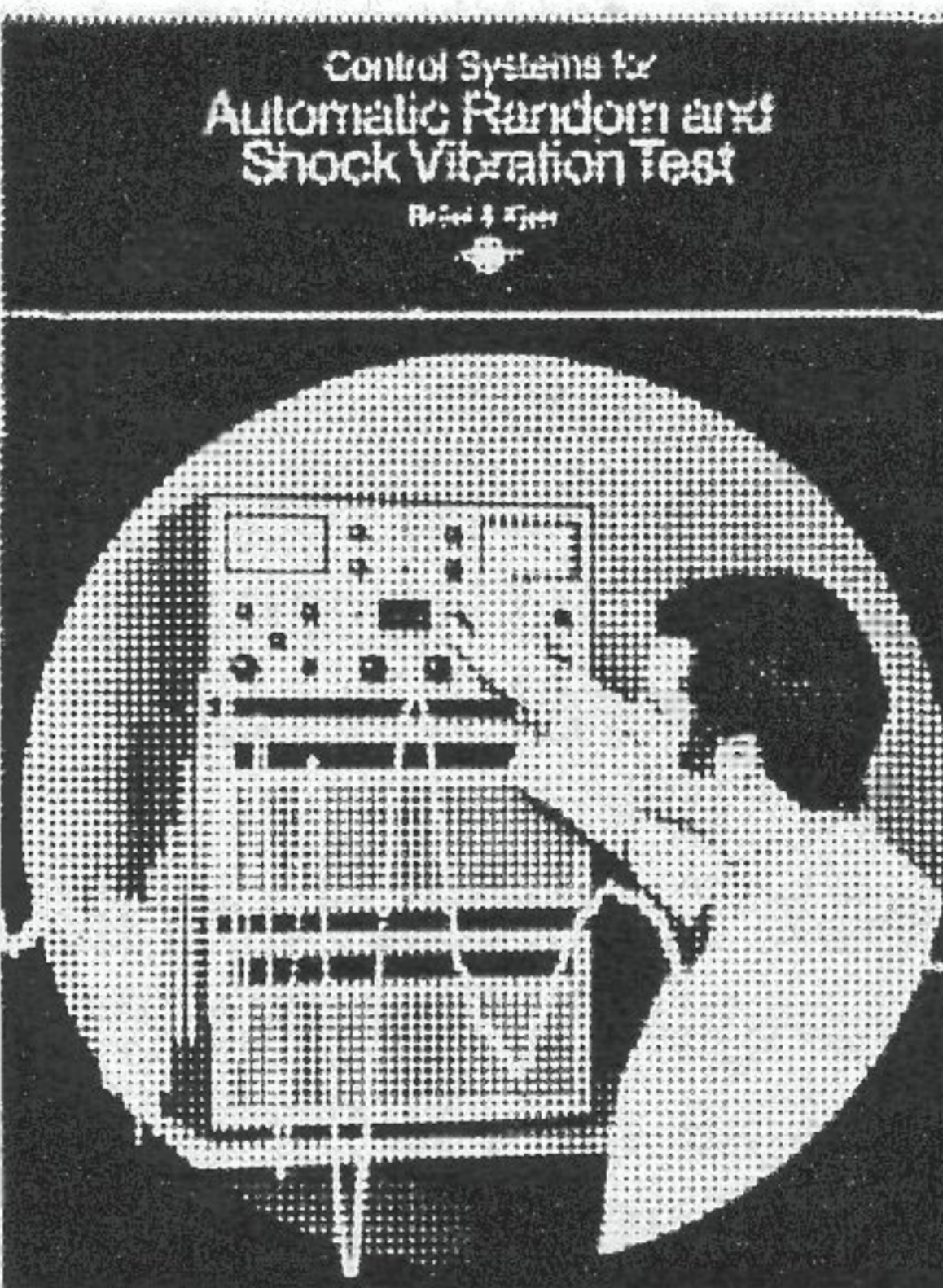
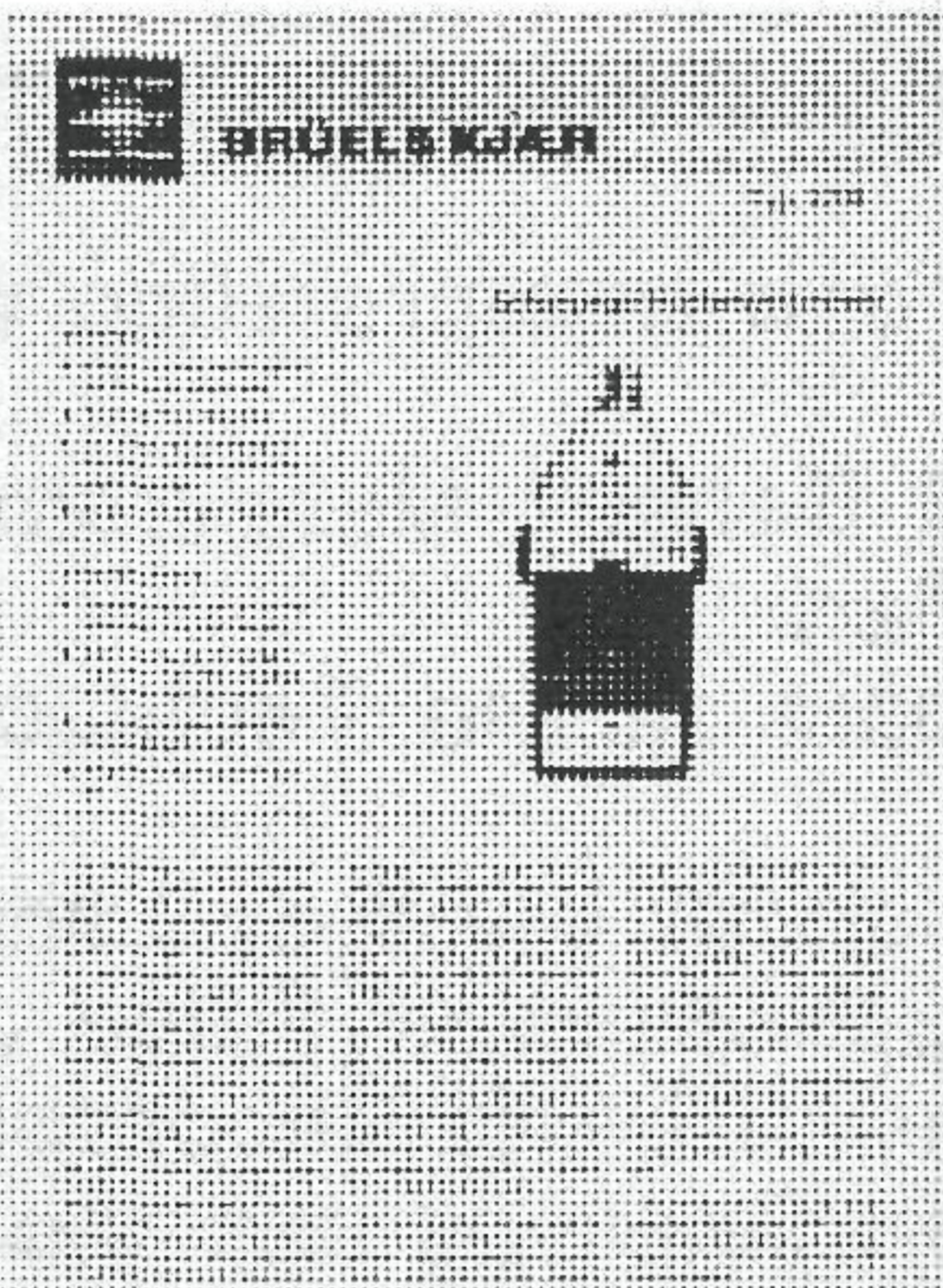
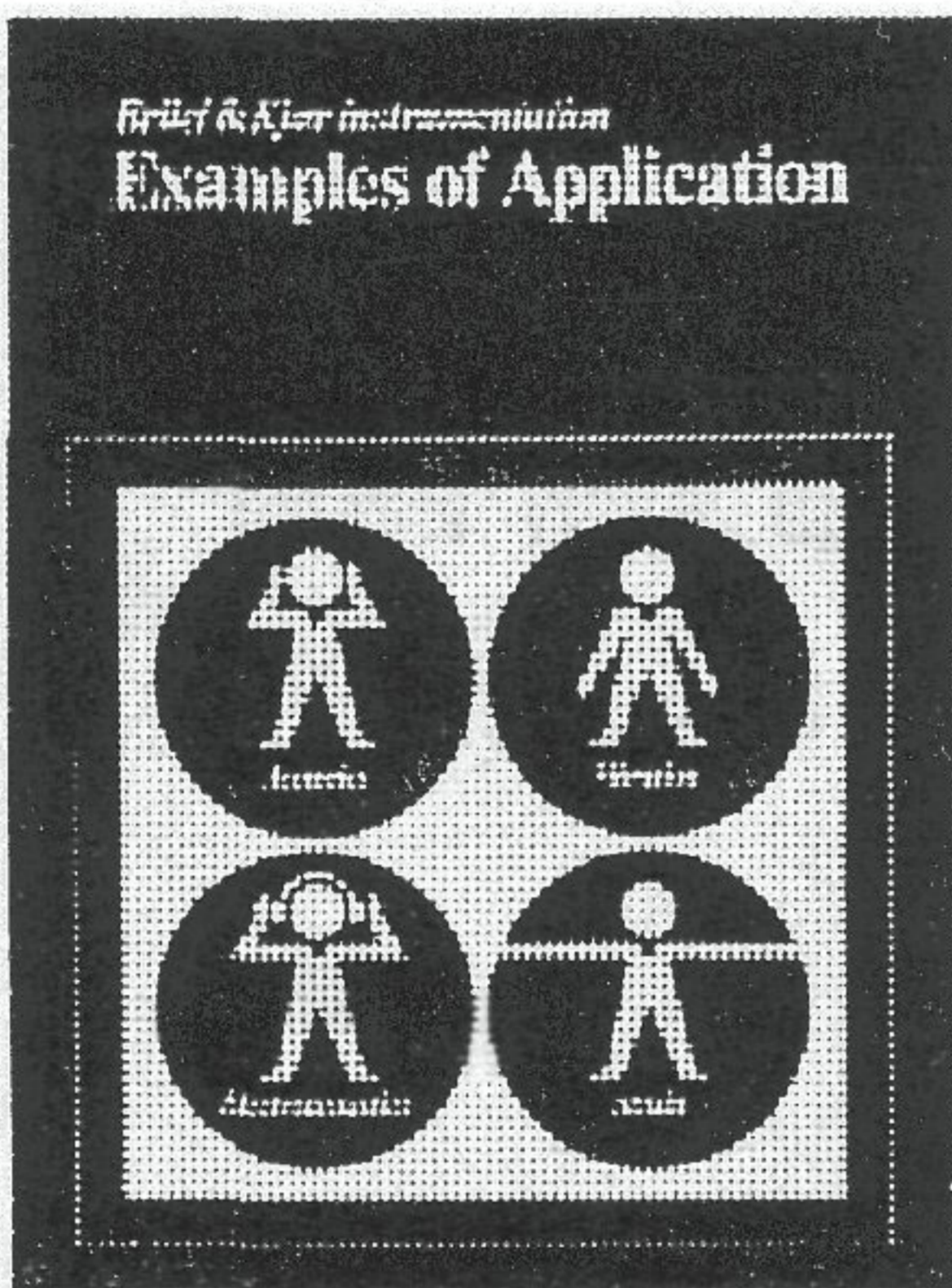
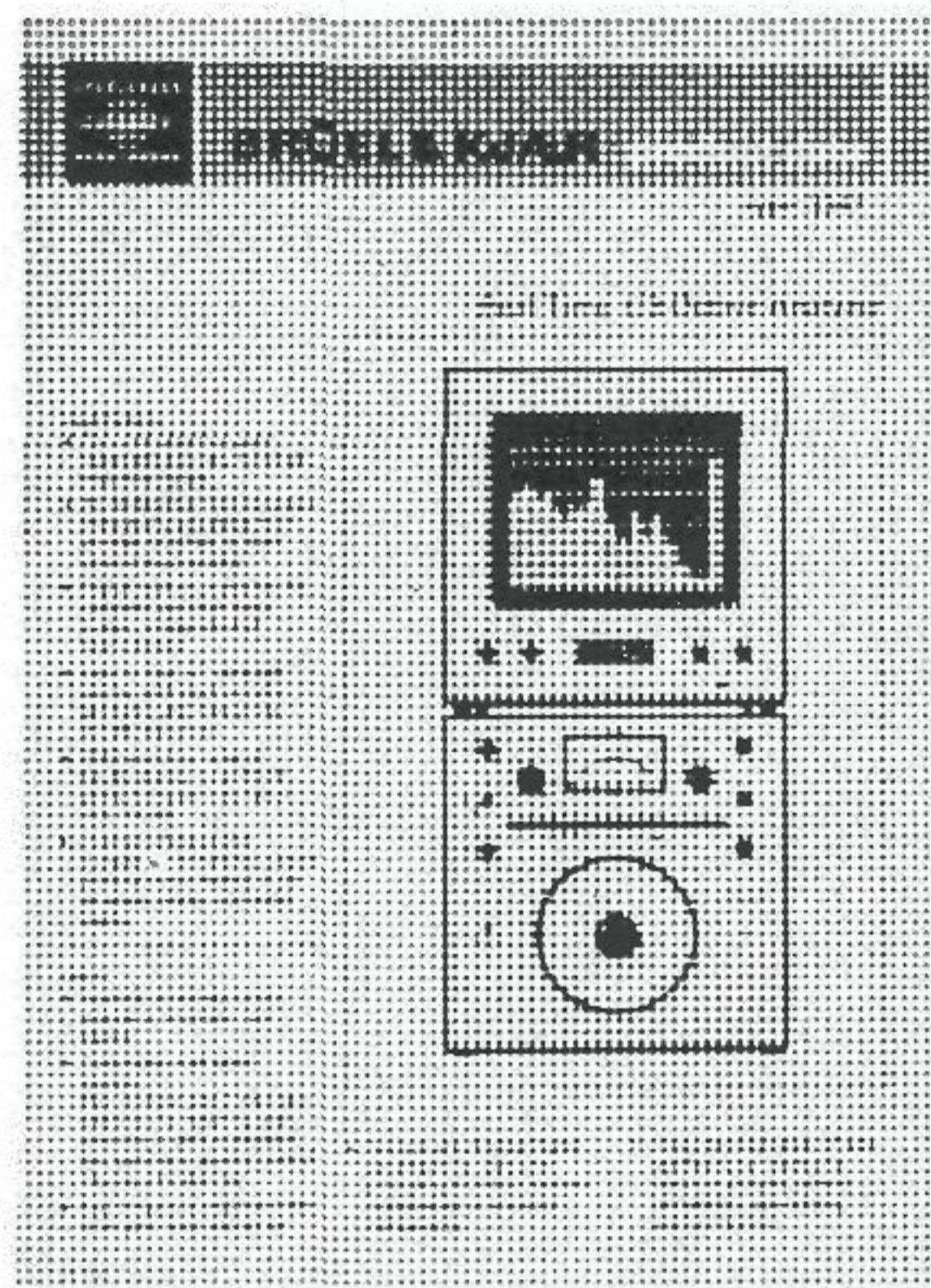

BRÜEL & KJÆR

DK-2850 Nærum, Denmark. Teleph.: (01) 80 05 00. Cable: BRUKJA, Copenhagen. Telex: 15316